

2003 - 2007 Ford Super Duty 6.0L Powerstroke ScanGauge II XGauge Codes

Version: 5

Updated: May 11, 2012

GAUGE	TXD	RXF	RXD	MTH	DESCRIPTION
AP%	07E02209D4	0462050906D4	3008	000100020000	Accelerator Pedal Position (%) Key On = 0 Low Idle = 0 Hi Idle = 13 Operating Range = 0-17.75
BAR	07E0221442	046285140642	3010	001D00500000	Barometric Pressure (kPa(PSI)). Alternate to BMP Key On = 96.5 (14) Low Idle = 96.5 (14) High Idle = 96.5 (14) Operating Range = 50-120 (7.3 - 17.4)
BAT	07E0221172	046205110672	3008	000100010000	Battery voltage (Volts)
BMP	07E0221127	045285110627	3008	003100500000	Barometric Press (inHg)
BST	07E0221440	046285140640	3010	01220320****	Boost (PSI). In order to get the proper boost value enter the MAP XGauge. Get a reading from it with the key in the on position but the engine off. Based on the reading change the last 4 digits of the MTH value that corresponds to your reading in the table to the right.
					14.0 -- FF74 14.1 -- FF73 14.2 -- FF72 14.3 -- FF71 14.4 -- FF70 14.5 -- FF6F 14.6 -- FF6E 14.7 -- FF6D 14.8 -- FF6C 14.9 -- FF6B 15.0 -- FF6A
CM1	07E022160E	04620516060E	3010	000100010000	Cylinder #1 cumulative misfires
CM2	07E022160F	04620516060F	3010	000100010000	Cylinder #2 cumulative misfires
CM3	07E0221610	046205160610	3010	000100010000	Cylinder #3 cumulative misfires
CM4	07E0221611	046205160611	3010	000100010000	Cylinder #4 cumulative misfires
CM5	07E0221612	046205160612	3010	000100010000	Cylinder #5 cumulative misfires
CM6	07E0221613	046205160613	3010	000100010000	Cylinder #6 cumulative misfires
CM7	07E0221614	046205160614	3010	000100010000	Cylinder #7 cumulative misfires

GAUGE	TXD	RXF	RXD	MTH	DESCRIPTION
CM8	07E0221615	046205160615	3010	000100010000	Cylinder #8 cumulative misfires
CVI	07E0221155	046245110655	3010	006433330000	VREF Calibration Voltage Input (Volts)
DTC	07E0220200	046205020600	3008	000100010000	Diagnostic Trouble Code Count
EBP	07E0221445	046285140645	3010	001D00500000	Exhaust Back Pressure (kPa(Psi)) Key On = 103 (15) Low Idle = 110 High Idle = 110 (16) Operating Range = 55-607 (8-88)
EBP	07E0221445	046285140645	3010	001D0050FFFB	Exhaust Back Pressure (-0.5 PSI bias)
ECT	07E0221139	046205110639	3008	000200010000	Engine Coolant Temperature (*F)
EGR	07E022166E	04620516066E	3010	006440000000	EGR Duty Cycle (%) Key On = 0 Low Idle = 0-15 High Idle 32 Operating Range = 0-44
EGV	07E022167E	04620516067E	3010	000133330000	EGR Valve Position (Volts 0-5) Key On = 0.8 Low Idle = 0.8-1.0 High Idle = 1.3 Operating Range = 0.6-3.5
EOT	07E0221310	046245130610	3010	00090005F060	Engine Oil Temperature (*F) Engine Hot: Key On = 190 Low Idle = 190 High Idle = 190 Operating Range = -40-302
EPV	07E02216AE	0462451606AE	3010	001309C40000	Exhaust Back Pressure Sensor Voltage (Volts) Key On = 0.8 Low Idle = 1.2 High Idle = 1.3 Operating Range = 0.4 - 4.7
ERT	07DF011F	0441051F	2810	0001003C0000	Engine Run Time (Minutes)

GAUGE	TXD	RXF	RXD	MTH	DESCRIPTION
ETP	07E022096C	04620509066C	3010	00647FFF0000	EGR Throttle Position Control Signal
EVD	07E022096A	04620509066A	3010	000100010000	EGR Valve Position in hundredths of a millimeter, where 0 mm indicates a closed EGR valve position
EVM	07E02209FE	0462050906FE	3010	00647FFF0000	EGR Valve Position Measured (%). Measured EGR Valve Position where a low value indicates a closed EGR valve (no EGR flow) and a high value indicates an open EGR valve. Key On = 0 Low Idle = 0 High Idle = 9.72 Operating Range = 0-14
EVP	07E022096A	04620509066A	3010	000100010000	EGR Valve Position (MM). EGR Valve Position in hundredths of a millimeter, where 0 mm indicates a closed EGR valve position.
FDC	07E022091F	04624509061F	3010	013103E80000	Fan Speed Sensor Duty Cycle (%)
FI1	07E02209EF	0462250906EF	3001	000100010000	Fuel Injector #1 Commanded on (On/Off)
FI2	07E02209EF	0462250906EF	3101	000100010000	Fuel Injector #2 Commanded on (On/Off)
FI3	07E02209EF	0462250906EF	3201	000100010001	Fuel Injector #3 Commanded on (On/Off)
FI4	07E02209EF	0462250906EF	3301	000100010002	Fuel Injector #4 Commanded on (On/Off)
FI5	07E02209EF	0462250906EF	3401	000100010003	Fuel Injector #5 Commanded on (On/Off)
FI6	07E02209EF	0462250906EF	3501	000100010004	Fuel Injector #6 Commanded on (On/Off)
FI7	07E02209EF	0462250906EF	3601	000100010005	Fuel Injector #6 Commanded on (On/Off)
FI8	07E02209EF	0462250906EF	3701	000100010006	Fuel Injector #7 Commanded on (On/Off)
FL	07E02216C1	0462451606C1	3010	000101480000	Fuel Level
FLP	07E02209EF	0462450906CF	3010	006401000000	FICM Logic Power (Volts). Should be 12 Key On = 12.0 Low Idle = 13.5 High Idle = 13.5 Operating Range = 10.5-15.5

GAUGE	TXD	RXF	RXD	MTH	DESCRIPTION
FMP	07E02209D0	0462450906D0	3010	006401000000	FICM Main Power (Volts). Should be 47-48 Key On = 47 Low Idle = 47.5 High Idle = 47.5 Operating Range = 40-52 Your FMP should never dip below 45. If it does, your FICM is toast and needs repaired or replaced
FPW	07E0221410	046205140610	3010	000800010000	Fuel Injector Pulse Width (Microseconds)
FSN	07E02209CD	0462050906CD	3601	000100010000	FICM Sync (0=No, 1=Yes)
FSS	07E022099F	04620509069F	3010	000100040000	Fan Speed Sensor (RPM)
FVP	07E02209CE	0462450906CE	3010	006401000000	FICM Vehicle Power (Volts). Should be 12 Key On = 12.0 Low Idle = 14.0 High Idle = 14.0 Operating Range = 10.5-15.5
GER	07E12211B3	0462051106B3	3008	000100020000	Gear
HPR	00	400080000000	0000	000A00240000	Horse Power
IA1	07E0221123	046205110623	3010	000100010000	Intake Air Temperture (*F)
IA2	07E02216A8	0462051606A8	3010	000100010000	Intake Air Temperture (*F)
ICP	07E0221446	046205140646	3010	003900640000	Injector Control Pressure (PSI) Key On = 0 Low Idle = 625.5 High Idle = 1400-1450
ICV	07E02216AD	0462451606AD	3010	004827100000	Injector Control Voltage (Volts) Key On = 0.2 Low Idle = 1.0 High Idle = 1.8
INJPW	07E0221410	046245140610	3010	044C04E2FFF1	FPW Microseconds (table)
INJPW	07E0221410	046205140610	3010	000800010000	FPW Microseconds (modified)

GAUGE	TXD	RXF	RXD	MTH	DESCRIPTION
IPR%	07E0221434	046285140634	3008	0DCA03E8000A	IPR Duty Cycle (%) Key On = 14.84 Low Idle = 24 High Idle = 40.60 Operating Range = 0-50
ITM	07E02209CC	0426850906CC	3010	000A00400000	Injector Timing Before Top Dead Center (Degrees) Key On = 0 Low Idle = 8.71 High Idle = +3.5 Operating Range = -50 - 50
MAP	07E0221440	046285140640	3010	012203200000	Manifold Air Pressure. Extended range. MAP is a standard gauge however this one has a larger range which is needed. The standard gauge tops out around 37 psi absolute (about 22 lbs of boost). This one should read well beyond 22 lbs of boost.
MAT	07E02216E0	0462051606E0	3008	00090005FFD8	Manifold Air Temperature (*F)
MAT	07E02216E0	0462051606E0	3010	001200050020	Manifold Air Temperature (*F). Alternate code
MFD	07E0221412	046245140612	3010	000100100000	Mass Fuel Desired (Milligrams per stroke)
MFD	07E0221412	046245140612	3010	006400100000	Mass Fuel Desired (inHg per stroke)
SYC	07E02209CD	0462050906CD	3000	000100010000	Camshaft & Crankshaft in sync (1 = in sync, 0 = not in sync)
SYC	07E02209CD	0462050906CD	3001	000100010000	Camshaft & Crankshaft in sync (1 = in sync, 0 = not in sync)
TFT	07E1221674	046205160674	3010	000100080000	Transmission Fluid Temperature (*F)
TP1	07E0220917	046245090617	3010	006404000000	Throttle Position 1 (Volts). Voltage of the ETC Throttle Position Sensor number 1 Key On = 4.0 Low Idle = 4.0 High Idle = 3.4 Operating Range = 0.7 - 4.2

GAUGE	TXD	RXF	RXD	MTH	DESCRIPTION
TPA	07E022093C	04624509063C	3010	0064020000000	Throttle Position Actual (Degrees). The measured throttle angle from the throttle sensor inputs.
TPC	07E022091A	04620509061A	3010	0020000010000	Throttle Position Commanded (Degrees)
TPD	07E022091A	04624509061A	3010	0064020000000	Throttle Position Desired (Degrees). ETC Commanded Throttle Angle
TRQ	07E02209CB	0462050906CB	3010	000100010000	Net Torque into Torque Converter (Ft-Lbs)
VFD	07E0221411	046245140611	3010	006400100000	Volume Fuel Desired (Milligrams per stroke) Key on = 0 Low Idle = 7.5 High Idle = 10.7 Operating Range = 0-100
VGT	07E022096D	04620509066D	3010	00647FFF0000	VGT Duty Cycle (%) Key On = 0 Low Idle = 73 High Idle = 43 Operating Range = 0-100
VSS	07E02211C1	0462051106C1	3010	000102000000	Vehicle Speed Sensor (MPH)

X-GAUGE™

Overview

While all OBDII compliant vehicles supply a "standard" set of data that ScanGauge can read, some makes and models of vehicles can supply additional information beyond the standard set of data.



Your ScanGauge features the exclusive X-GAUGE™ Programmable Gauge System that provides you a method to tap into this additional information. The X-GAUGE feature allows you to extend the capabilities of your ScanGauge to include things like: vehicle specific gauges, trip data as gauges, and special function gauges.

Programming a new X-GAUGE and saving it to your ScanGauge is simple and easy. Each X-GAUGE consists of specific alpha-numeric strings, or "codes," you enter into the ScanGauge via the front panel push buttons.

An extensive library of X-GAUGE codes for many different vehicles can be found on our Web site at www.scangauge.com/support

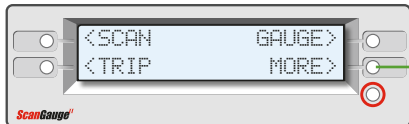

Accessing X-GAUGE Features

From the Home Screen, press the lower right function button twice, next to MORE.

Next, use the upper left and right function buttons to cycle through the available options until the screen titled X-GAUGE appears.

Finally, press the lower right function button next to EDIT to enter X-GAUGE.

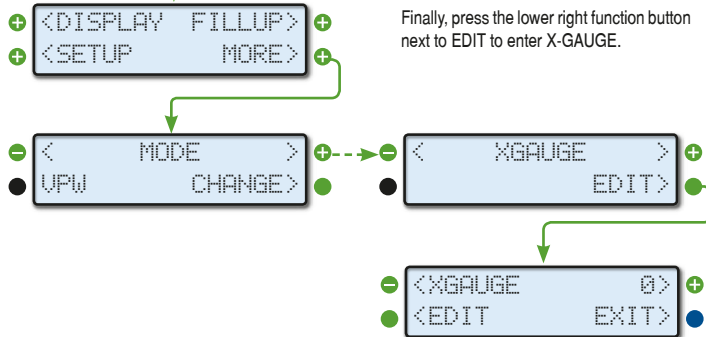

The X-GAUGE Home Screen

From the X-GAUGE Screen, pressing the upper left and upper right buttons allows you to cycle through the 25 available memory slots (0-24). Each memory slot can store an individual X-GAUGE.

If the memory slot is in use, the 3-letter name for the gauge will be shown in the top line next to the memory number. If no name is shown, this memory slot is not being used.

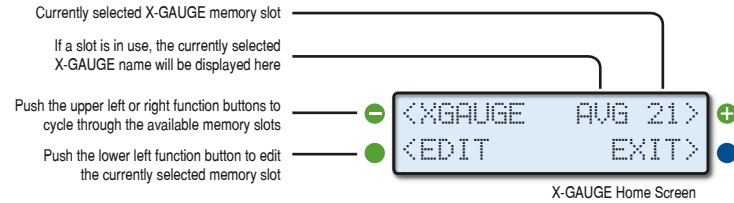

Add or Edit an X-GAUGE

To add a custom X-GAUGE to your ScanGauge, you will need to program the gauge parameters into the ScanGauge using the X-GAUGE Program Parameters Screens. In order to read the data from the vehicle and set up a functional X-GAUGE, you need to have the following information:

- Command to send
- How to identify a response to the command
- Where to find the data in the response
- How to scale, offset and display the data.

The X-GAUGE Program Parameter Screen

An X-GAUGE is entered into the ScanGauge through a series of X-GAUGE Program Parameters. Each X-GAUGE consists of 4 program parameter screens — TXD, RXF, RXD and MTH — as well as one gauge name screen.

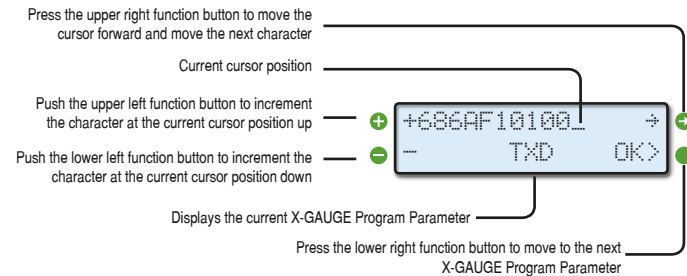

Programming Your Own X-GAUGE

Step 1 - Select an Empty Memory Slot

Start by selecting an empty memory slot by using the upper left and right buttons. Next, press the EDIT button.

Step 2 - Enter the TXD Data

The TXD on the lower line means that the value being entered is the command that will be transmitted to the vehicle's computer.



IMPORTANT: Entries must be an even number of characters. If an odd number of characters is entered, a 0 will be appended to the string to make it even.

A nonspace entry must be made in the first character location, or the X-GAUGE will not be an active gauge.

If the TXD value is blank, no name will be shown; and this X-GAUGE memory will not appear as a selectable gauge.

Step 3 - Enter the RXF Data

The RXF Screen is the entry for the receive filter. This value tells the ScanGauge what to look for in a response from the vehicle's computer.

Also, some of the entries tell the ScanGauge how to display the data. Choices are integer, tenths, hundreds, hexadecimal or on/off. There are also some fields that can turn any trip value into a gauge. When you're done, press the OK button to proceed to the next step.

Step 4 - Enter the RXD Data

The RXD Screen is the entry that tells the ScanGauge where the data and its size are in the response. Entry in this screen is done the same as the other X-GAUGE entry screens. When you're done, press the OK button to proceed to the next step.

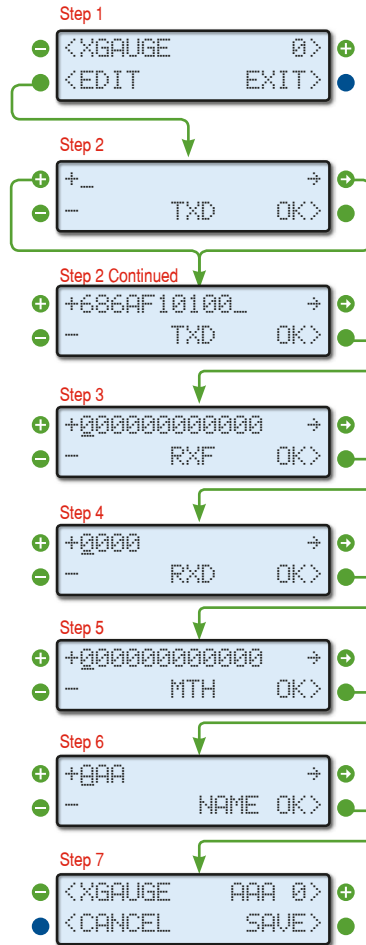

Step 5 - Enter the MTH Data

The MTH (math) screen tells the ScanGauge the math needed to scale and/or offset the value received for the X-GAUGE entry screens. When you're done, press the OK button to proceed to the next step.

Step 6 - Give Your Gauge a Name

The Name Screen allows you to input a 3-letter designator for the name of the gauge you are making. This screen allows a complete ASCII set of characters to be used. This includes punctuation and symbols. You can give the gauge any 3-character name. Please note, you can give your new gauge a name that matches those that are already defined. This should be avoided as it can cause confusion.

When you're done, press the OK button to proceed to the next step.

Step 7 - Saving Your X-GAUGE

To save your new X-GAUGE programming, press the lower right function button next to SAVE. If you wish to discard the changes you have made, press CANCEL. This will cause all the modifications to the X-GAUGE memory slot to be canceled and not saved.



Pressing SAVE will return you to the X-GAUGE Home Screen. The new X-GAUGE name will also appear in the top line, next to the memory slot number.

Copying an X-GAUGE To a Different Memory Slot

If you want to program a new X-GAUGE that is very similar to one you have already entered, you can copy the program parameter data in one X-GAUGE memory slot to another.

Step 1 - Select an X-GAUGE to Copy

Start by selecting the X-GAUGE you would like to copy. Use the upper left and right function buttons to cycle through the X-GAUGE memory slots until you locate the X-GAUGE you want to copy. Next press the lower left function button next to EDIT.

Steps 2-6 - Edit The Program Parameters

Step through the settings and edit the selected X-GAUGE's program parameters as needed for the new X-GAUGE.

Step 7 - Change Memory Slot and Save

Before pressing SAVE, use the upper left and right function buttons to select a new memory slot.

If an asterisk (*) is present in the top line next to the new X-GAUGE name, then there is already an

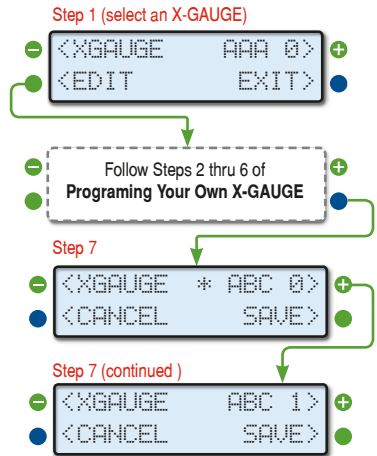

Saving an X-GAUGE in a particular memory slot will overwrite any X-GAUGE data that may already be saved in that memory slot.

X-GAUGE saved in that memory slot. Saving the new X-GAUGE in that particular slot will overwrite any X-GAUGE data already present in that memory slot. Once you have the desired memory slot selected, press lower right function button next to SAVE. All the data will be written to that X-GAUGE memory slot, leaving the previously selected memory slot unchanged.

Disabling an X-GAUGE

To disable an X-GAUGE already in memory, start as if you were going to edit the gauge. In the TXD Screen, change the first character to a space. Continue to step through the editing fields by pressing the lower right function button next to OK and press SAVE to exit the screen. This will actually delete the data to transmit, which tells the ScanGauge not to use this X-GAUGE. The name will not be displayed. If you put transmit data back into this gauge, it will be reactivated.

Displaying a Trip Value as an X-GAUGE

You can set any of the built-in trip values and have them displayed as a gauge. This allows you to monitor trip functions along with other gauge functions.

In the example to the right, a custom X-GAUGE that displays the Time Driven Today is set up.

Step 1

To get started, choose an empty memory slot from the X-GAUGE Screen. Then press the lower left function buttons next to EDIT.

Step 2

In the TXD Screen, the first character determines which trip function will be displayed. Choose a number from the **Available Trip Parameters** chart on the next page.

The second character determines which trip to use. Choose a number from the **Trip Designations** chart on the next page.

When you're done, press the lower right function button next to OK to move to the next screen.

Step 3

For RXF, make the first character an 8 as shown to the right.

An 8 as the first character is a special condition that tells the ScanGauge that this is to be a trip gauge. All values after the 8 are ignored.

When you're done, press the lower right function button next to OK to move to the next screen.

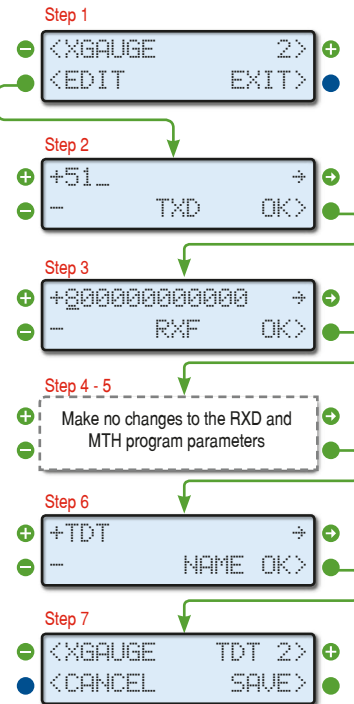

Steps 4 and 5

Do not make any changes to the RXD and MTH screens. Simply press the lower right function button next to OK until you reach the name screen.

Available Trip Parameters	
Parameter	Trip Name
0	Average Fuel Economy
1	Fuel used
2	Max Coolant Temperature or Fuel Remaining for TANK trip
3	Distance
4	Max RPM or Distance to Empty for TANK trip
5	Time
6	Max Speed or Time to Empty for TANK trip
7	Average Speed
8	Cost

Step 6

Enter a name for your new X-GAUGE. For this example, we used TDT for Time Driven Today. When you're done, press the lower right function button next to OK, to move to the next screen.

Step 7

To complete this X-GAUGE, press lower right function button next to SAVE. Once saved, the new X-GAUGE will be available on the GAUGE screen along with other gauges (see page 23).

Trip Designations	
Designation	Trip Name
0	Current Trip
1	Today's Trip
2	Previous Day's Trip
3	Tank Trip

Using an X-GAUGE

After an X-GAUGE has been created, it can be selected like any other gauge. In the Gauge screen (see page 23), press the function button next to the gauge position you want to use for the X-GAUGE. Keep pressing as needed until the X-GAUGE name appears.

For instance, if the following screen were visible, pressing the button next to RPM a number of times would eventually reach TDT.

