

11-1 FUSE PANEL/CIRCUIT PROTECTION

2001 EXCURSION, SUPER DUTY SERIES F-250, F-350, F-450, F-550

CIRCUIT PROTECTION DEVICES

Electrical circuits on this vehicle may be protected by fuses, fusible links, fusible link cartridges, circuit breakers, or a combination of these devices.

BLADE TYPE FUSE

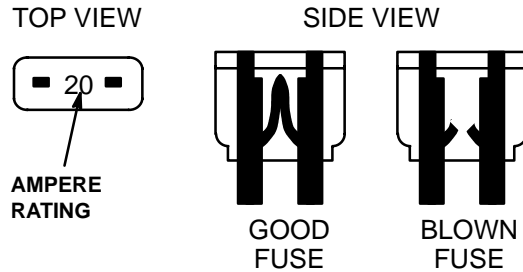

Blade type fuses have a transparent plastic housing. To check a fuse, pull it from the fuse panel and look at the fuse element through the housing. Always replace a blown fuse with a new fuse that has the same ampere rating.

The ampere rating of a blade type fuse can also be determined by following the color code shown here:

BLADE FUSE COLOR CODING	
AMPERE RATING	HOUSING COLOR
3	Violet
4	Pink
5	Tan
10	Red
15	Light Blue
20	Yellow
25	Natural
30	Light Green

FUSIBLE LINK

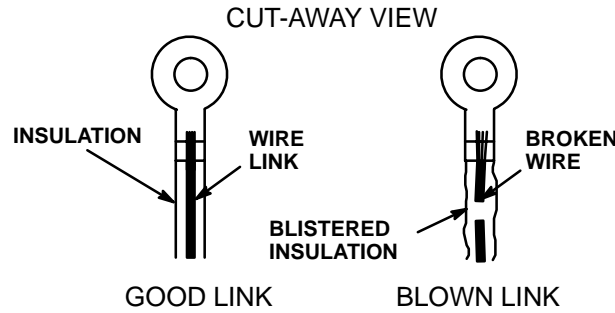

Fusible links are short lengths of wire that are smaller in diameter than the wires they are protecting. Fusible link wire is covered with a special thick, non-flammable insulation. An overload condition causes the insulation to blister. If the overload condition continues, the wire link will melt. To check a fusible link, look for blistered insulation. If the insulation is okay, pull lightly on the wire; if the fusible link stretches, the wire has melted.

When replacing fusible links, first cut the protected wire where it is connected to the fusible link. Then, tightly crimp or solder the new link to the protected wire.

Fusible links are often identified by color coding of the insulation, as shown here:

FUSIBLE LINK COLOR CODING	
WIRE LINK SIZE	INSULATION COLOR
20 GA	Blue
18 GA	Brown or Red
16 GA	Black or Orange
14 GA	Green
12 GA	Gray

MAXI-FUSE CARTRIDGE

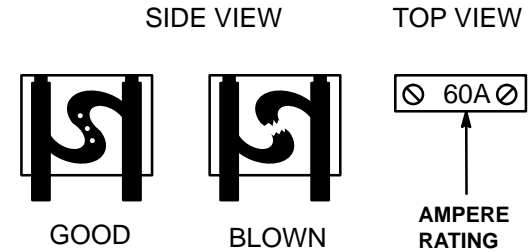

Maxi-fuse cartridges have a transparent colored plastic housing. To check a maxi-fuse cartridge, look at the fuse element through the side of the housing.

To replace a maxi-fuse cartridge, pull it from the fuse box or panel. Always replace a blown maxi-fuse cartridge with a new one having the same ampere rating.

The ampere rating of a maxi-fuse cartridge can also be determined by following the color code shown here:

MAXI-FUSE CARTRIDGE COLOR CODING	
AMPERE RATING	HOUSING COLOR
30	Light Green
40	Amber
50	Red
60	Blue

FUSE PANEL/CIRCUIT PROTECTION 11-2

2001 EXCURSION, SUPER DUTY SERIES F-250, F-350, F-450, F-550

CIRCUIT BREAKER

Some circuits are protected by circuit breakers (abbreviated "c. b." in fuse chart). They can be Fuse Panel mounted or in-line. Like fuses, they are rated in amperes.

Each circuit breaker conducts current through an arm made of two types of metal bonded together (bimetal arm). If the arm starts to carry too much current, it heats up. As one metal expands faster than the other the arm bends, opening the contacts. Current flow is broken. A circuit breaker can be the cycling or non-cycling type.

FUSE PANEL MOUNTED CYCLING TYPE

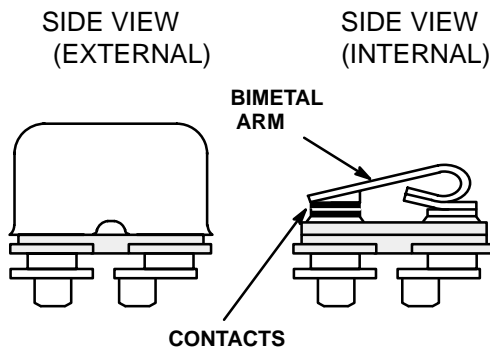

IN-LINE MOUNTED CYCLING TYPE

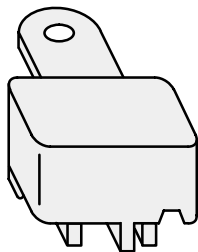

In the cycling type, the bimetal arm cools and straightens out. This cycle repeats as long as the overcurrent exists and power is applied.

FUSE PANEL MOUNTED NON-CYCLING TYPE

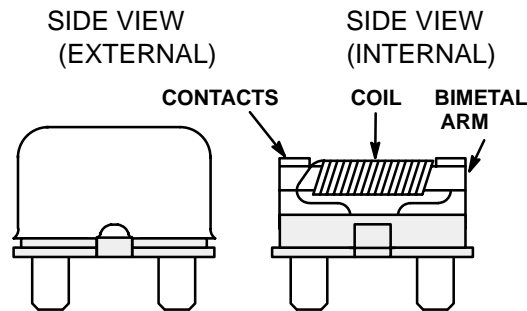

In the first type, there is a coil wrapped around the bimetal arm. When an overcurrent exists and the contacts open, a small current passes through the coil. This current through the coil is not enough to operate a load, but it does heat up both the coil and the bimetal arm. This keeps the arm in the open position until power is removed.

In the second type, a spring pushes the bimetal arm down and holds the contacts together. When an overcurrent condition exists and the bimetal arm heats up, the bimetal arm bends enough to overcome the spring and the contacts snap open. The contacts stay open until the reset button is pushed and the contacts snap together again.

FUSE PANEL MOUNTED MANUAL RESET TYPE

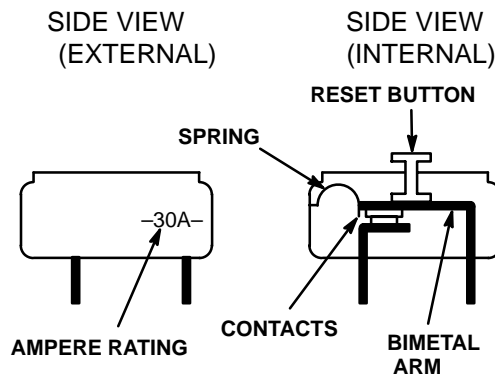

Two types of non-cycling circuit breakers are used; one is reset by removing power from the circuit, and the other is reset by depressing a reset button.

DIODE

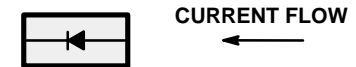

Diodes are electrical devices that permit current to flow in one direction only. The current flows in the direction indicated by the arrow.

MEGA FUSE



Mega fuse protects the charging circuit. In the event that the mega fuse is blown due to the charging circuit failure, the generator field circuit is disabled.

11-3 FUSE PANEL/CIRCUIT PROTECTION

2001 EXCURSION, SUPER DUTY SERIES F-250, F-350, F-450, F-550

EXCURSION

BATTERY JUNCTION BOX

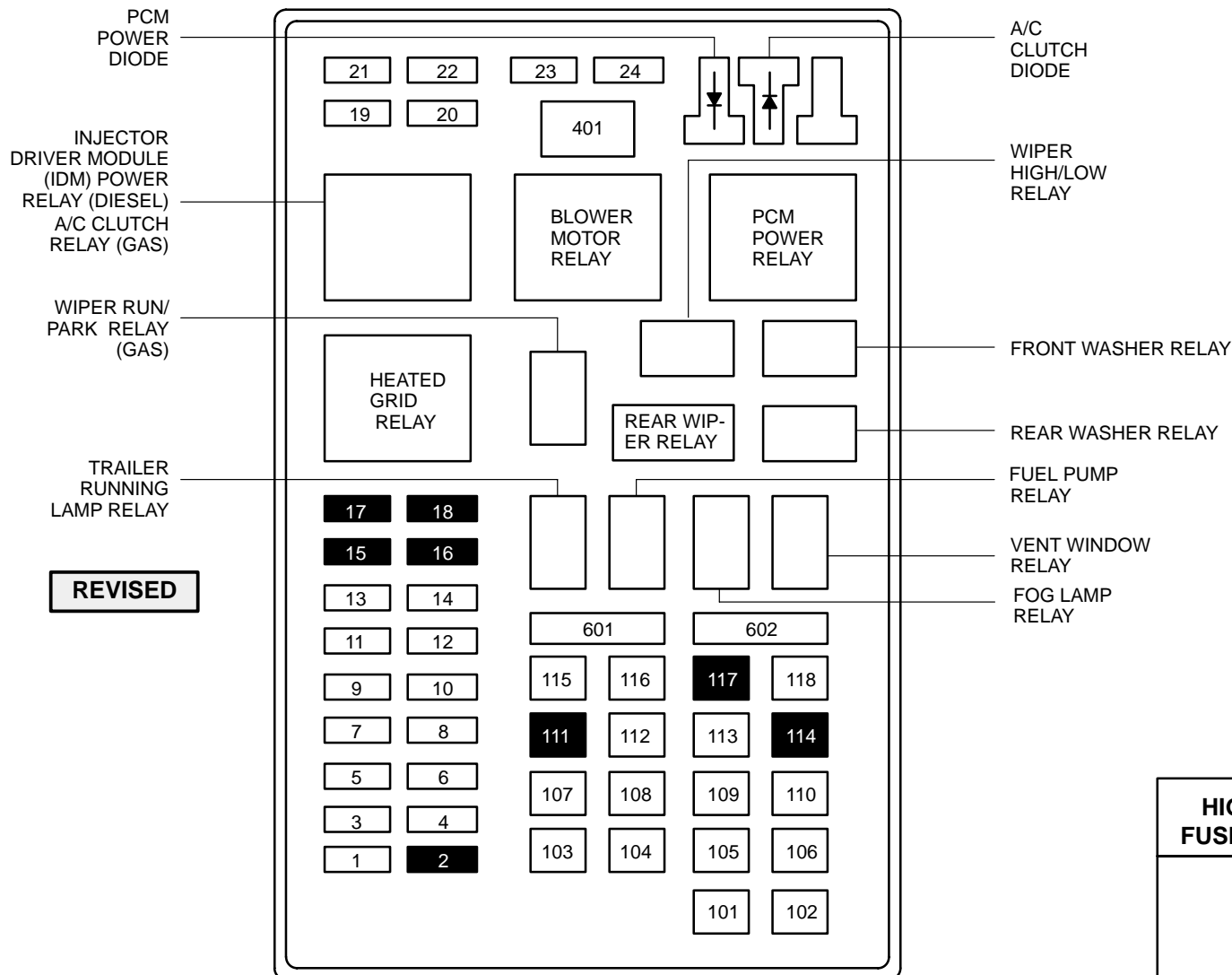

HIGH CURRENT FUSE VALUE AMPS	COLOR CODE
20A PLUG-IN	YELLOW
30A PLUG-IN	GREEN
40A PLUG-IN	ORANGE
50A PLUG-IN	RED
60A PLUG-IN	BLUE

FUSE PANEL/CIRCUIT PROTECTION 11-4

2001 EXCURSION, SUPER DUTY SERIES F-250, F-350, F-450, F-550

EXCURSION

Mini Fuses	Amps	Circuits Protected
1	20	Rear Wipers
2	–	NOT USED
3	15	Vent Window Relay
4	20	Trailer Tow Reversing Lamp Relay, Trailer Tow Park Lamp Relay
5	20	I/P Power Point
6	10	A/C Clutch Relay (Gas)
6	10	Generator Field (Diesel), A/C Clutch Relay (Gas)
7	20	Floor Console Power Point
8	15	Park Lamps
9	20	Left Rear Power Point
10	30	Headlamps, DRL, Fog Lamps
11	20	Cargo Power Point
12	15	Daytime Running Lamps (DRL), Fog Lamps
13	10	Front Washer Pump/Rear Washer Pump
14	15	Horn Relay
15	5	Fog Lamps
16	–	NOT USED
17	–	NOT USED
18	–	NOT USED
19	20	Heated Oxygen Sensors (HO2S) (Gas)
20	7.5	Trailer Tow Connector (Left Turn)
21	10	LH Headlamp
22	7.5	Trailer Tow Connector (Right Turn)
23	10	RH Headlamp
24	20	Powertrain Control Module (PCM) (GAS)

Maxi Fuses	Amps	Circuits Protected
101	50	Ignition Switch
102	30	Power Locks
103	40	Auxiliary Blower
104	30	Electronic Shift on the Fly
105	50	Central Junction Box
106	30	Injector Driver Module Power Relay (Diesel)
107	30	Heated Seats
108	30	Power Seats
109	40	Front Blower Motor
110	30	Trailer Brake Controller
111	30	NOT USED
112	20	Fuel Pump
113	20	Powertrain Control Module Power Relay (Diesel)
113	30	Powertrain Control Module Power Relay (Gas)
114	–	NOT USED
115	30	Trailer Battery Charge Relay
116	50	Ignition Switch
117	–	NOT USED
118	40	Heated Backlite
401	–	NOT USED
601 C.B.	30	Accessory Delay Relay (Power Windows)
602	60	4WABS

11-5 FUSE PANEL/CIRCUIT PROTECTION

2001 EXCURSION, SUPER DUTY SERIES F-250, F-350, F-450, F-550

EXCURSION

CENTRAL JUNCTION BOX

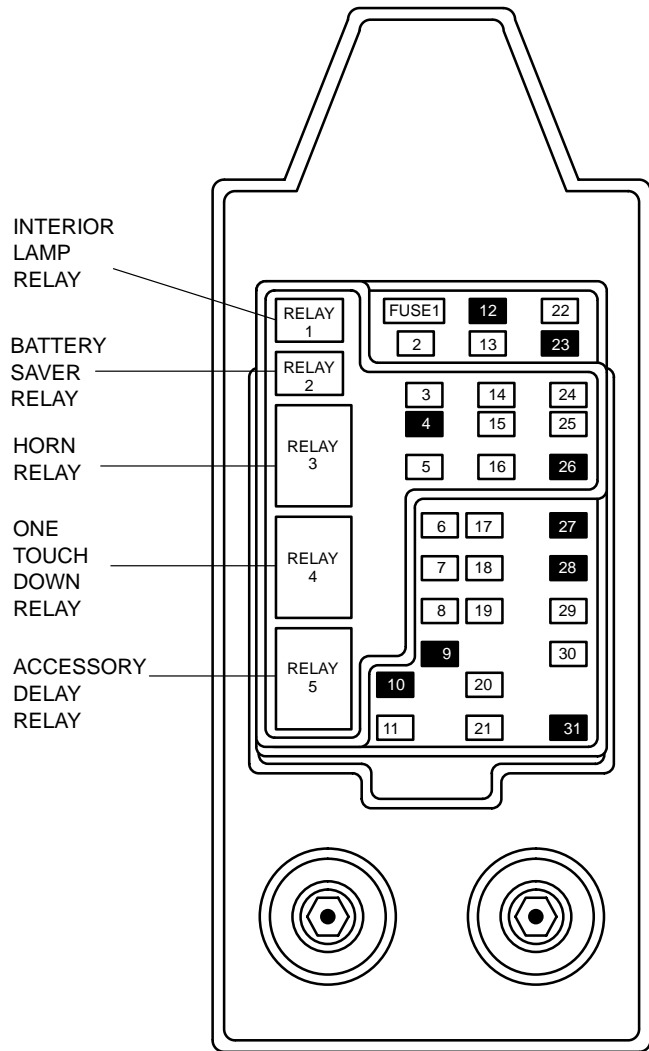

TOP VIEW

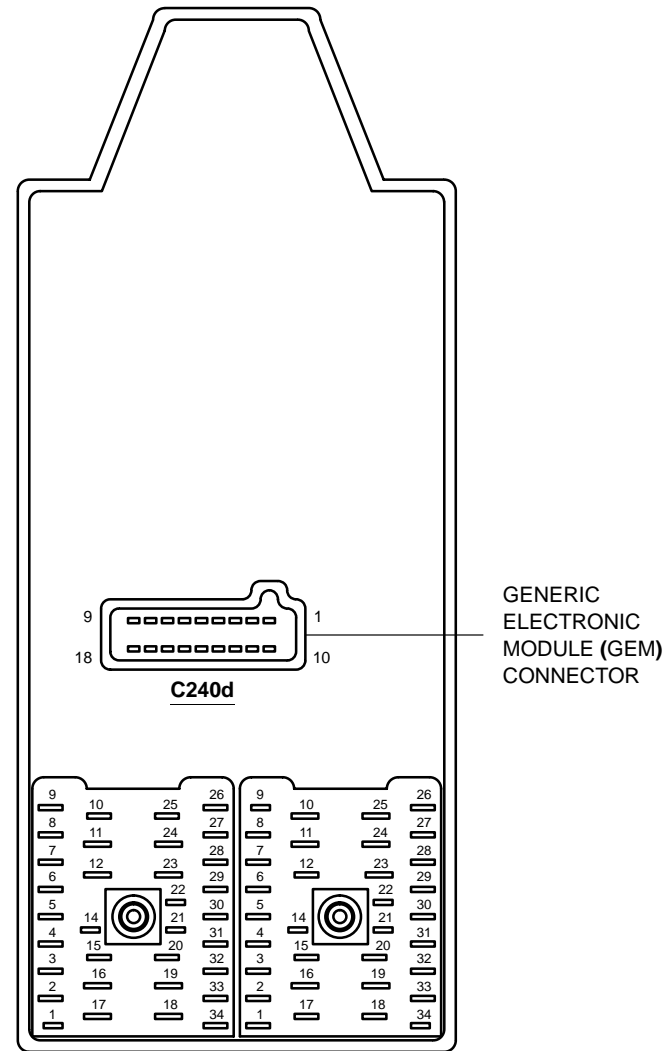

BOTTOM VIEW

FUSE PANEL/CIRCUIT PROTECTION 11-6

2001 EXCURSION, SUPER DUTY SERIES F-250, F-350, F-450, F-550

EXCURSION

*DIESEL

REVISED

Fuse Position	Amps	Circuits Protected
1	20	Radio
2	5	Instrument Cluster
3	20	Cigar Lighter, Data Link
4	–	NOT USED
5	–	NOT USED
6	–	NOT USED
7	5	<i>Power Window Switch Illumination, Video Display, Video Player</i>
8	5	Radio, Main Light Switch
9	–	NOT USED
10	–	NOT USED
11	30	Washer Pump Relays, Wiper Run/Park Relay, Wiper High/Low Relay
12	–	NOT USED
13	20	Brake Pedal Position (BPP) Switch, Stoplamps, Hazzard Lamps, Speed Control
14	15	Interior Lamp Relay, Battery Saver Relay
15	5	Generic Electronic Module (GEM), Brake Pedal Position (BPP) Switch, Passive Anti-Theft System (PATS) Module
16	15	Instrument Cluster, High-Beam Indicator, High-Beam Headlamps
17	–	NOT USED
18	10	<i>Radio, Rear Seat Entertainment (RSE) Module</i>
19	10	Instrument Cluster, GEM Module, Overdrive Cancel Switch, Idle Validation Switch, Passive Anti-Theft Module
20	15	Generic Electronic Module (GEM), Digital Transmission Range (DTR) Sensor
21	5	Audio (Start Feed)
22	10	Blower Motor Relay, Air Bag Diagnostic Module
23	10	Air Bag Diagnostic Module
24	10	Blend Door Actuator, Trailer Battery Charge Relay, A/C Clutch, Rear Window Defrost/Heated Mirrors
25	5	Anti-Lock Brake System (ABS) Module
26	–	NOT USED
27	10	Customer Access
28	15	Daytime Running Lamps (DRL), Powertrain Control Module (PCM), Flasher Relay, Reversing Lamps, Vacuum Pump, Heated Backlite Relay, Electronic Shift on the Fly Solenoid, Auxiliary A/C
29	5	Instrument Cluster (Charge, Air Bag Warning Lamps)
30	30	Radio Noise Capacitor, Coil on Plug, PCM Power Diode
*30	30	Fuel Heater, Waste Gate, Injector Driver Module Relay
31	15	Heated Grid Relay, Rear Window Defrost Grid, Rear Window Defrost Switch, Right Heated Exterior Rear View Mirror, Left Heated Exterior Rear View Mirror

11-7 FUSE PANEL/CIRCUIT PROTECTION

2001 EXCURSION, SUPER DUTY SERIES F-250, F-350, F-450, F-550

BATTERY JUNCTION BOX

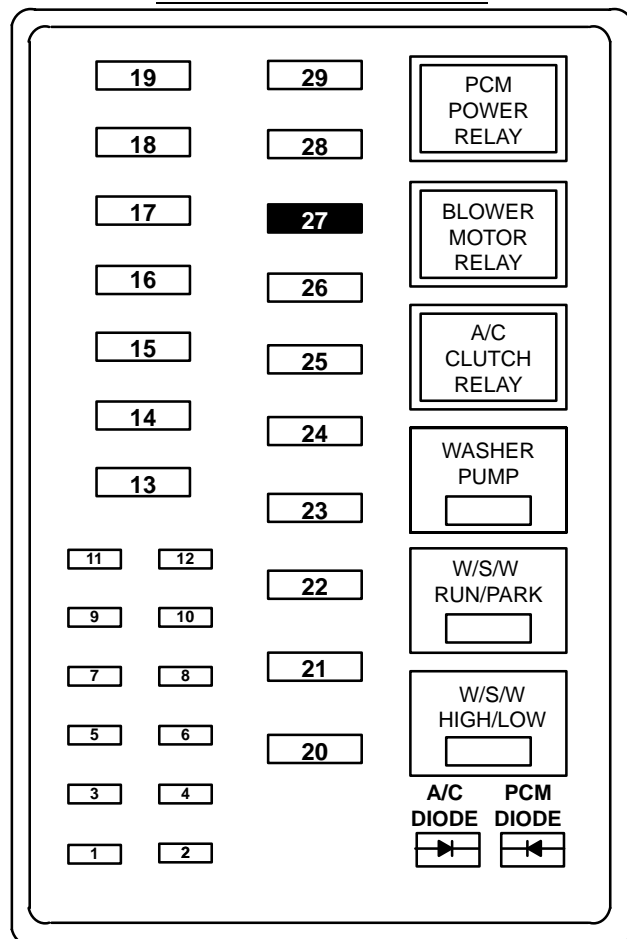

HIGH CURRENT FUSE VALUE AMPS	COLOR CODE
20A PLUG-IN	YELLOW
30A PLUG-IN	GREEN
40A PLUG-IN	ORANGE
50A PLUG-IN	RED
60A PLUG-IN	BLUE

GASOLINE PICKUP

Fuse Position	Amps	Circuits Protected
1	7.5(Mini)	Trailer Tow Package
2	10(Mini)	Washer Pump Relay
3	7.5(Mini)	Trailer Tow Package
4	20(Mini)	Trailer Reversing Lamp Relay, Trailer Running Lamp Relay
5	20(Mini)	Electronic Engine Controls
6	10 (Mini)	A/C Clutch Relay
7	20(Mini)	Electronic Engine Controls
8	15(Mini)	Main Light Switch, Park Lamp Relay
9	10(Mini)	Left Headlamp
10	20(Mini)	Auxiliary Power Socket
11	10(Mini)	Right Headlamp
12	15(Mini)	DRL Resistor, Fog Lamp Relay
13	30(Maxi)	Main Light Switch, Multifunction Switch
14	60(Maxi)	Anti-Lock Brake System (ABS) Module
15	30(Maxi)	Heated Seats
16	30(Maxi)	Trailer Battery Charge Relay
17	30(Maxi)	Transfer Case Shift Relay
18	30(Maxi)	Power Seat Control Switch
19	20(Maxi)	Fuel Pump Relay
20	50(Maxi)	Ignition Switch (B4 & B5)
21	50(Maxi)	Ignition Switch (B1 & B3)
22	50(Maxi)	Central Junction Box Battery Feed
23	40(Maxi)	Blower Relay
24	30 (Maxi)	PCM Power Relay, PDB Fuses 5, 7
25	30(CB)	Central Junction Box, Accessory Delay Relay, Power Windows
26	20(Maxi)	All Unlock Relay, All Lock Relay, Driver Unlock Relay, LH Power Door Lock Switch, RH Power Door Lock Switch, Park Lamp Relay
27	-	NOT USED
28	30(Maxi)	Trailer Electronic Brake Controller
29	20(Maxi)	Radio

FUSE PANEL/CIRCUIT PROTECTION 11-8

2001 EXCURSION, SUPER DUTY SERIES F-250, F-350, F-450, F-550

BATTERY JUNCTION BOX

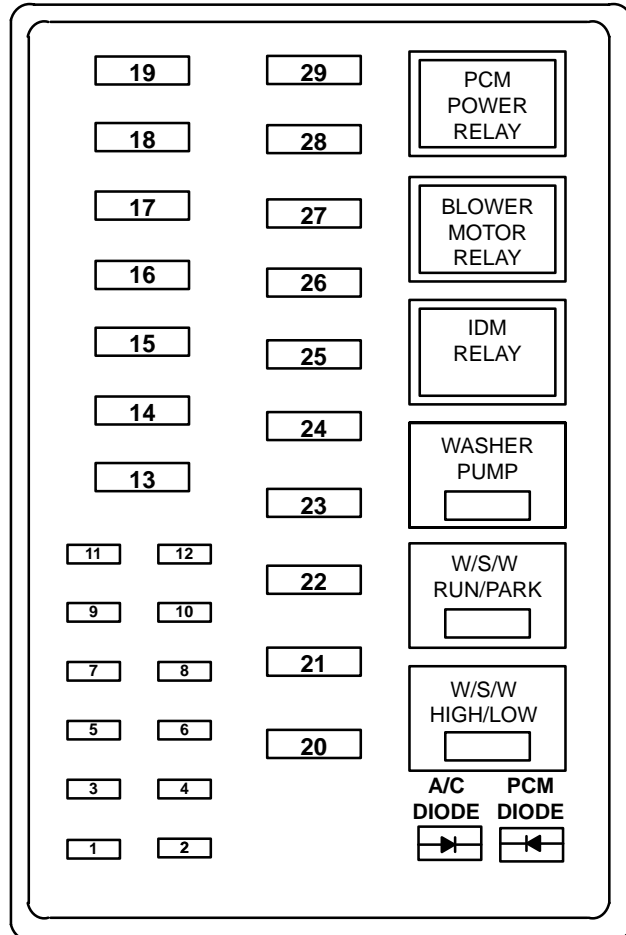

HIGH CURRENT FUSE VALUE AMPS	COLOR CODE
20A PLUG-IN	YELLOW
30A PLUG-IN	GREEN
40A PLUG-IN	ORANGE
50A PLUG-IN	RED
60A PLUG-IN	BLUE

DIESEL PICKUP

*DUAL GENERATOR

Fuse Position	Amps	Circuits Protected
1	7.5(Mini)	Trailer Tow Package
2	10(Mini)	Washer Pump Relay
3	7.5(Mini)	Trailer Tow Package
4	20(Mini)	Trailer Reversing Lamp Relay, Trailer Park Lamp Relay
* 5	5(Mini)	Generator (Secondary)
6	10(Mini)	Generator, PDB Fuses 5,7
*7	5(Mini)	Generator
8	15(Mini)	Main Light Switch
9	10(Mini)	Left Headlamp
10	20(Mini)	Auxiliary Power Socket
11	10(Mini)	Right Headlamp
12	15(Mini)	DRL Resistor
13	30(Maxi)	Main Light Switch, Multifunction Switch, Headlamps
14	60(Maxi)	Anti-Lock Brake System (ABS) Module
15	30(Maxi)	Heated Seats
16	30(Maxi)	Trailer Battery Charge Relay
17	30(Maxi)	Transfer Case Shift Relay
18	30(Maxi)	Power Seat Control Switch
19	20(Maxi)	Fuel Pump Relay
20	50(Maxi)	Ignition Switch (B4 & B5)
21	50(Maxi)	Ignition Switch (B1 & B3)
22	50(Maxi)	Central Junction Box Battery Feed
23	40(Maxi)	Blower Relay
24	20(Maxi)	PCM Power Relay
25	30(CB)	Central Junction Box, Accessory Delay Relay, Power Windows
26	20(Maxi)	All Unlock Relay, All Lock Relay, Driver Unlock Relay, LH Power Door Lock Switch, RH Power Door Lock Switch, Park Lamp Relay
27	30(Maxi)	IDM Relay
28	30(Maxi)	Trailer Electronic Brake Controller
29	20(Maxi)	Radio

11-9 FUSE PANEL/CIRCUIT PROTECTION

2001 EXCURSION, SUPER DUTY SERIES F-250, F-350, F-450, F-550

PICKUP

CENTRAL JUNCTION BOX

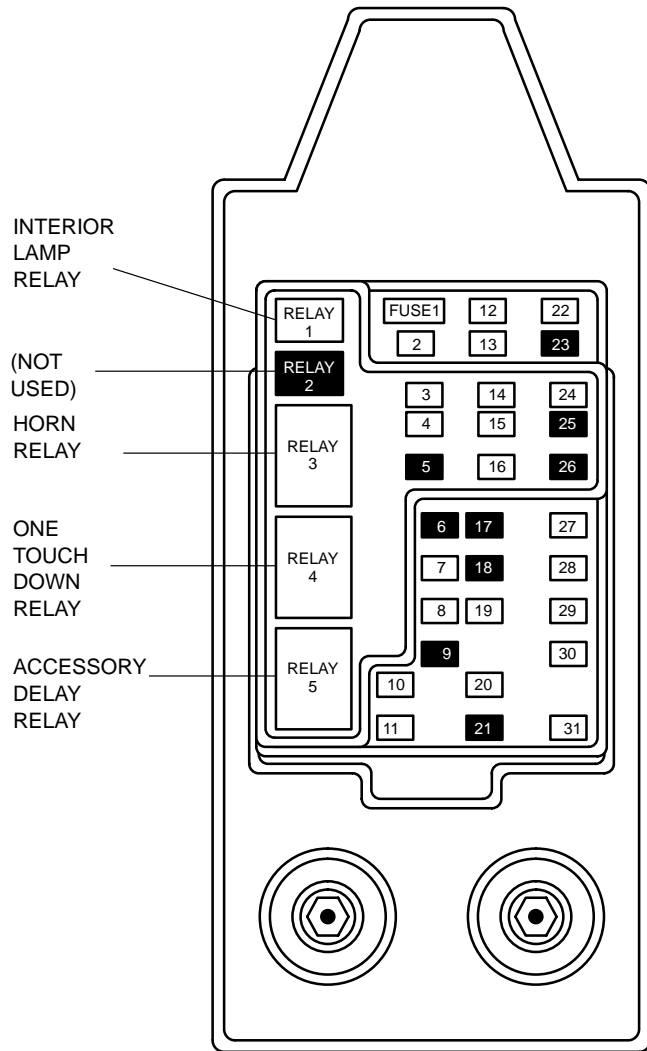

TOP VIEW

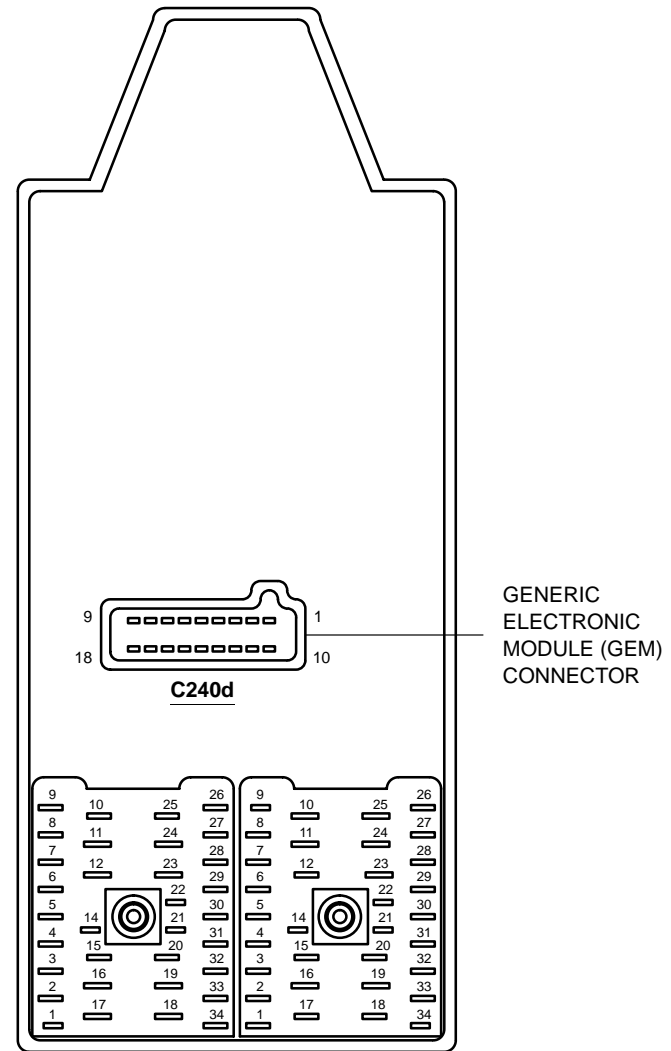

BOTTOM VIEW

FUSE PANEL/CIRCUIT PROTECTION 11-10

2001 EXCURSION, SUPER DUTY SERIES F-250, F-350, F-450, F-550

*DIESEL

PICKUP

Fuse Position	Amps	Circuits Protected
1	20	Flasher Relay
2	–	NOT USED
3	20	Cigar Lighter, Data Link
4	10	Glove Box Lamp, Map Lamps, Power Mirrors, Underhood Lamp, Accessory Delay Relay, Vanity Lamps
5	–	NOT USED
6	–	NOT USED
7	5	Power Window Switch Illumination, Power Door Lock Switch Illumination
8	5	Radio, GEM
9	–	NOT USED
*10	15	Fuel Tank Selector Switch
11	30	Washer Pump Relays, Wiper Run/Park Relay, Wiper High/Low Relay, Wiper Motor
12	15	Horn Relay, Horn
13	20	Brake Pedal Position (BPP) Switch, Brake Pressure Switch
14	10	Interior Lamp Relay
15	5	Generic Electronic Module (GEM), Brake Pedal Position (BPP) Switch, Instrument Cluster, Powertrain Control Module (PCM)
16	15	Instrument Cluster, High-Beam Indicator, High-Beam Headlamps
17	–	NOT USED
18	5	Radio
19	10	Auxiliary Powertrain Control Module, Instrument Cluster, GEM Module, Overdrive Cancel Switch, Clutch Switch, Idle Validation Switch, Overhead Console, Dash Reset Relay (Bi-Fuel)
20	15	Generic Electronic Module (GEM), Clutch Pedal Position/Jumper
21	–	NOT USED
22	10	Blower Motor Relay, Passenger Air Bag Deactivation Switch
23	10	Air Bag Diagnostic Module
24	10	Blend Door Actuator, Climate Control Switch, Trailer Battery Charge Relay, Flasher Relay, Anti-Lock Brake System (4WABS)
25	–	NOT USED
26	–	NOT USED
27	10	Customer Access
28	15	Brake Shift Interlock, DRL Relay, Speed Control Module, Vacuum Pump Motor, Hublock Solenoid, Reversing Lamp Switch, Digital Transmission Range (DTR) Sensor, Heated Seats, Parking Aid Module
29	5	Instrument Cluster (Charge, Air Bag Warning Lamps)
30	30	Radio Noise Capacitor, Coil on Plug, PCM Power Diode
*30	30	Fuel Filter, Waste Gate
31	5	Fog Lamps

11-11 FUSE PANEL/CIRCUIT PROTECTION

2001 EXCURSION, SUPER DUTY SERIES F-250, F-350, F-450, F-550

BI-FUEL RELAY MODULE

PICKUP

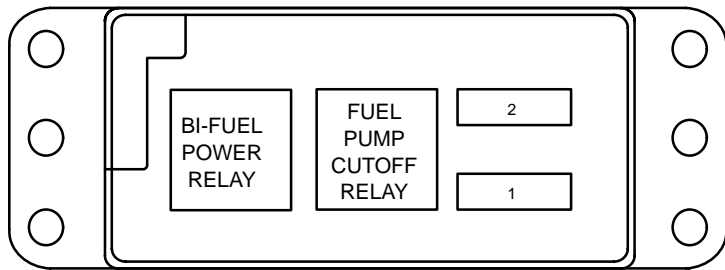

Fuse Position	Amps	Circuits Protected
1	3	Compuvalve Module
2	10	Bi-Fuel Power Relay, Low Flow Injector Assembly, High Flow Injector Assembly

