

93-94

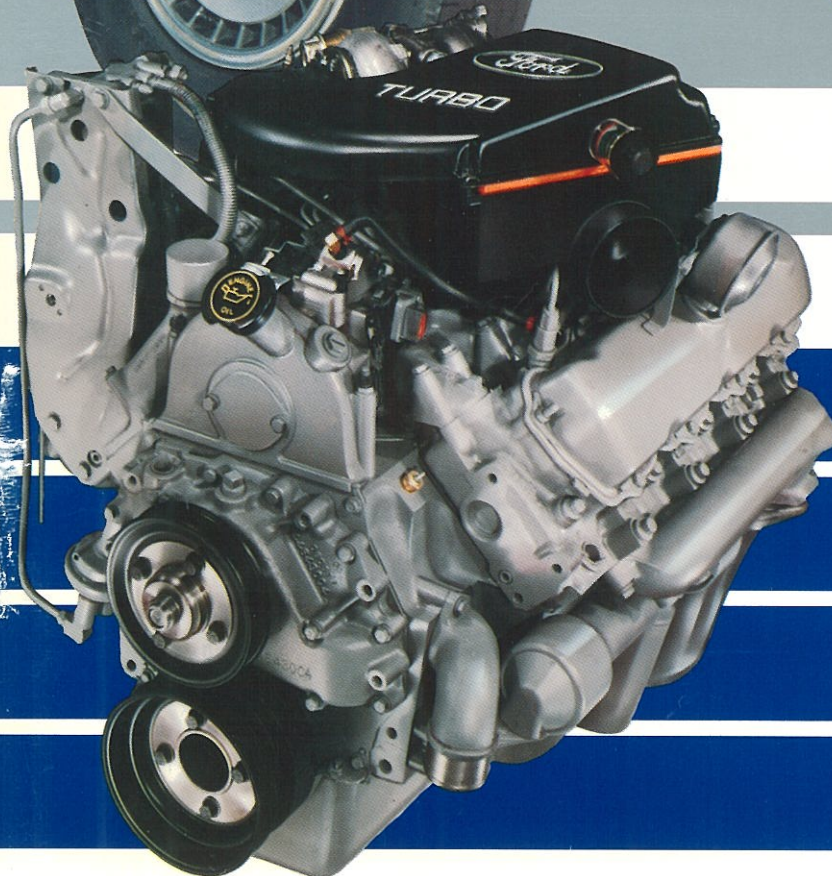

7.3L IDI

TURBOCHARGED

DIESEL

ENGINE

FOREWORD

This publication is intended to provide technicians and service personnel with the latest technical advancements incorporated in the 7.3L IDI Turbocharged Diesel Engine. The information contained in this publication will supplement information contained in available service literature.

IMPORTANT SAFETY NOTICE

Appropriate service methods and proper repair procedures are essential for the safe, reliable operation of all motor vehicles, as well as the personal safety of the individual doing the work. This manual provides general directions for accomplishing service and repair work with tested, effective techniques. Following them will help assure reliability.

There are numerous variations in procedures, techniques, tools, and parts for servicing vehicles, as well as in the skill of the individual doing the work. This manual cannot possibly anticipate all such variations and provide advice or cautions as to each. Accordingly, anyone who departs from the instructions provided in this manual must first establish that he comprises neither his personal safety nor the vehicle integrity by his choice of methods, tools or parts.

The following list contains some general **WARNINGS** that you should follow when you work on a vehicle.

- Always wear safety glasses for eye protection.
- Use safety stands whenever a procedure requires you to be under the vehicle.
- Be sure that the ignition switch is always in the **OFF** position, unless otherwise required by the procedure.
- Never perform any service to the engine with the air cleaner removed and the engine running unless a turbocharger compressor inlet shield is installed. Reference instructions on page 36.
- Set the parking brake when working on the vehicle. If you have an automatic transmission, set it in **PARK** unless instructed otherwise for a specific service operation. If you have a manual transmission, it should be in **REVERSE** (engine OFF) or **NEUTRAL** (engine ON) unless instructed otherwise for a specific service operation.
- Operate the engine only in a well-ventilated area to avoid the danger of carbon monoxide.
- Keep yourself and your clothing away from moving parts when the engine is running, especially the fan, belts, and the turbocharger compressor.
- To prevent serious burns, avoid contact with hot metal parts such as the radiator, turbocharger pipes, exhaust manifold, tail pipe, catalytic converter and muffler.
- Do not smoke while working on the vehicle.
- To avoid injury, always remove rings, watches, loose hanging jewelry, and loose clothing before beginning to work on a vehicle. Tie long hair securely behind the head.
- Keep hands and other objects clear of the radiator fan blades.

TABLE OF CONTENTS

7.3 LITER IDI TURBOCHARGED DIESEL ENGINE

	Page		Page
INTRODUCTION	2	Turbocharged Power Cylinder Components	24
OPTIONAL IN F-SERIES TRUCKS	3	Connecting Rod	24
7.3L-7.3L IDI TURBOCHARGED COMPARISON	4	Piston Pin	25
TURBOCHARGER BASIC FLOW & THEORY	5	Anodized Piston Head	25
TURBOCHARGER LEGEND	6	Piston Rings Keystone Design	25
TURBOCHARGER LUBRICATION LEGEND	7	Ring Groove Measurement	26-27
POWER CURVE COMPARISON	8	Exhaust Valve	27
TORQUE CURVE COMPARISON	8	EXTERNAL MODIFICATIONS	27
SPECIFICATIONS CHART	9	Oil Cooler Bundle	27
PHYSICAL IDENTIFICATION	10	Flywheel	28
Engine Serial Number	10	Vibration Damper	28
Calibration Label	10	Fuel Injection Pump	28-29
Emissions Label	10	Fuel Injection Nozzle	29
EXTERNAL FEATURES	11	Fuel Return Line	29
AIR CLEANER ASSEMBLY	11	TURBOCHARGED ENGINE DIAGNOSTICS	30
TURBOCHARGER ASSEMBLY	11	DIAGNOSTIC FORMS	30
EXHAUST CROSSOVER PIPE	11	DIAGNOSTIC CHANGES	30
TURBOCHARGER PACKAGE	12	BOOST TEST	30-32
TURBOCHARGER ASSEMBLY	13	WASTEGATE ACTUATOR TEST	32-34
TURBOCHARGER ID PLATE	13	AIR FILTER RESTRICTION TEST	34-35
A/R RATIO	14	INJECTION PUMP TIMING TEST	35
TURBINE A/R RATIO	14	INJECTION PUMP TIMING	35
CROSSOVER PIPE	15	INJECTION PUMP TRANSFER PRESSURE TEST	36-37
"Y" COLLECTOR	15	NOZZLE TEST	38
EXHAUST INLET CASTING	15	CRANKCASE PRESSURE TEST	38-40
WASTEGATE	16	SERVICE TIPS	40
WASTEGATE ACTUATOR	16	TURBO REMOVAL	41-46
MARMON CLAMP	16	TURBO INSPECTION	46
PEDESTAL	17	Check End Play	46
AIR CHAMBER	18	Check Radial Movement	46
OIL MANIFOLD	18	TURBO COMPONENT REPLACEMENT	47
TURBOCHARGER OIL SUPPLY	18	Center Section Replacement	47-51
TURBOCHARGER OIL LINE	19	Wastegate Actuator Removal	51-52
HEAT SHIELDING	19	Wastegate Actuator Installation	53-54
TURBINE/EXHAUST HEAT SHIELD	19	Turbo Installation	54-59
AIR CLEANER ASSEMBLY	20	Injection Pump Removal	59-60
AIR CLEANER ELEMENT	20	Injection Pump Installation	60
FILTER MINDER	20	Torque Angle	61-63
VALVE COVERS	21	Test Air Induction	63-65
LEFT VALVE COVER	21	CHASSIS CHANGES	65
RIGHT VALVE COVER	21	BUMPER SLOTS	65
ENGINE WIRING HARNESS	22	AIR DAM	66
DESIGN MODIFICATIONS	23	E40D DIPSTICK	66
INTERNAL PARTS CHANGES	24	E40D MICROPROCESSOR	66
Head Gasket	24	EXHAUST SYSTEM	67
		FAN CLUTCH	67
		APPENDIX	
		SERIAL NUMBER BREAK LISTING	A1
		ENGINE PERFORMANCE CHART	
		DIAGNOSTIC GUIDE	A2

INTRODUCING



1

7.3L IDI TURBOCHARGED DIESEL ENGINE INTRODUCTION

2

7.3L IDI TURBOCHARGED DIESEL ENGINE F-SERIES

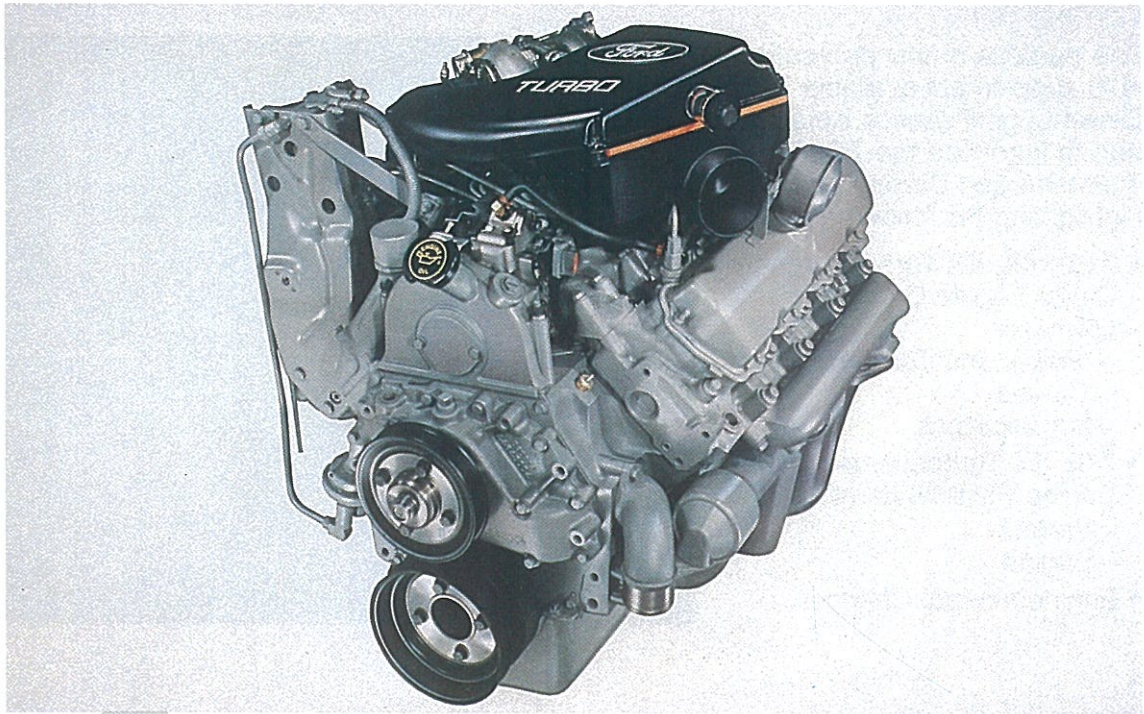

2

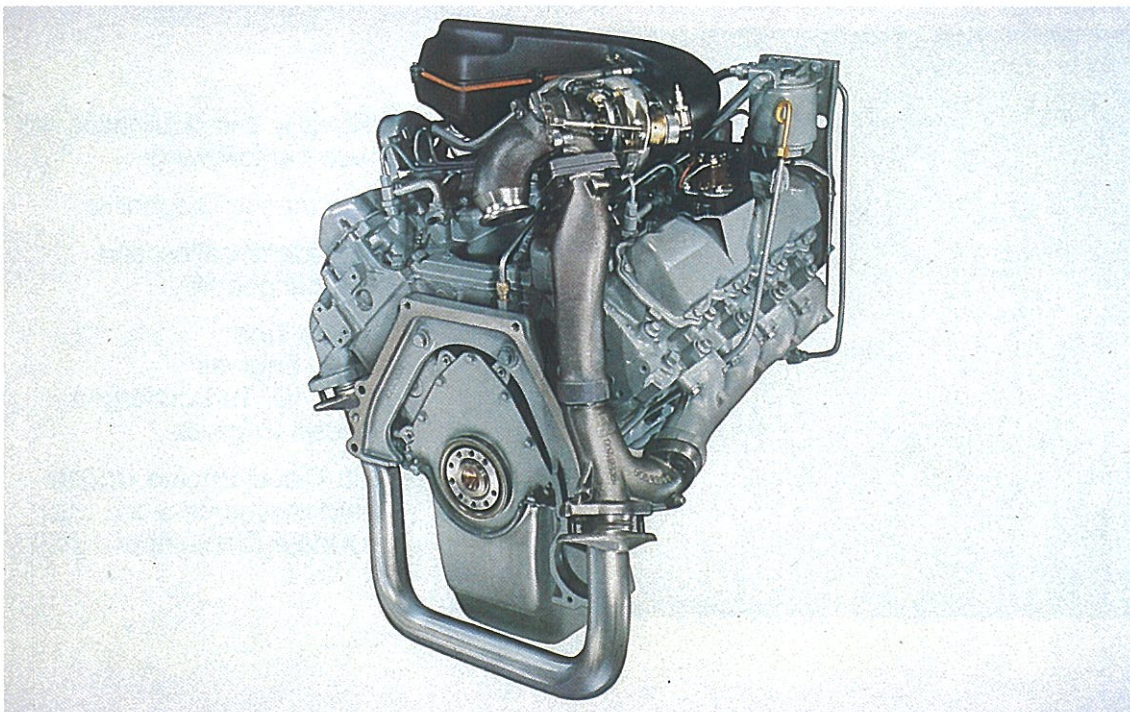

3

The 7.3L IDI Turbocharged Diesel Engine will be optional in the F-Series trucks.

3

7.3L IDI TURBOCHARGED DIESEL ENGINE

The purpose of this publication is to supplement available 7.3L Diesel Engine service literature and to introduce the 7.3L IDI Turbocharged Diesel Engine highlighting the following areas:

- 7.3L-7.3L IDI Turbocharged Diesel Engine Comparison Overview
 - Power and Torque Curves
 - Specifications
- 7.3L IDI Turbocharged Diesel Engine Physical Identification
 - Vehicle
 - Engine
- Engine Internal Changes

- **7.3L-7.3L IDI TURBOCHARGED DIESEL ENGINE COMPARISON OVERVIEW**
 - **POWER AND TORQUE CURVES**
 - **SPECIFICATIONS**
- **7.3L IDI TURBOCHARGED DIESEL ENGINE PHYSICAL IDENTIFICATION**
 - **VEHICLE**
 - **ENGINE**
- **ENGINE INTERNAL CHANGES**

4

- **PERFORMANCE DIAGNOSTICS**
- **PARTS IDENTIFICATION AND INTERCHANGEABILITY**
- **SERVICE TIPS**
 - **7.3L ENGINES**
 - **7.3L IDI TURBOCHARGED DIESEL ENGINE**
- **7.3L DIESEL ENGINE UPDATE**
 - **IMPROVEMENTS SINCE LAST UPDATE (SEPTEMBER 1987)**

Additionally this publication will discuss the following:

- Performance Diagnostics
- Parts Identification and Interchangeability
- Service Tips
 - 7.3L Engines
 - 7.3L IDI Turbocharged Diesel Engines
- 7.3L Diesel Engine Update
 - Improvements Since Last Update (September 1987)

5

TURBOCHARGER BASIC FLOW AND THEORY

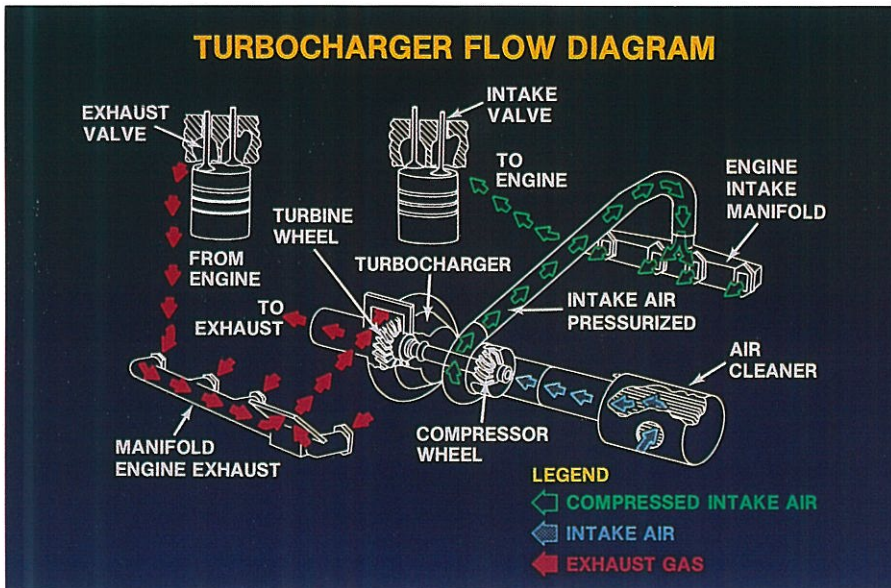

6



7

A turbocharger is a relatively simple air pump used to increase the volume and density of air available for combustion in an engine.

A turbocharger consists of a turbine, which is driven by exhaust gases exiting the engine. This turbine is attached to the compressor by a common shaft supported by two bushings.

Turbocharger operation raises the pressure delivered to the combustion chamber.

This increase in air pressure presented to the combustion chamber with the properly metered quantity of fuel results in an increase in engine performance and efficiency.

This feature will allow the engine to deliver rated levels of performance, irrespective of atmospheric conditions up to 10,000 feet elevation.

5

TURBOCHARGER

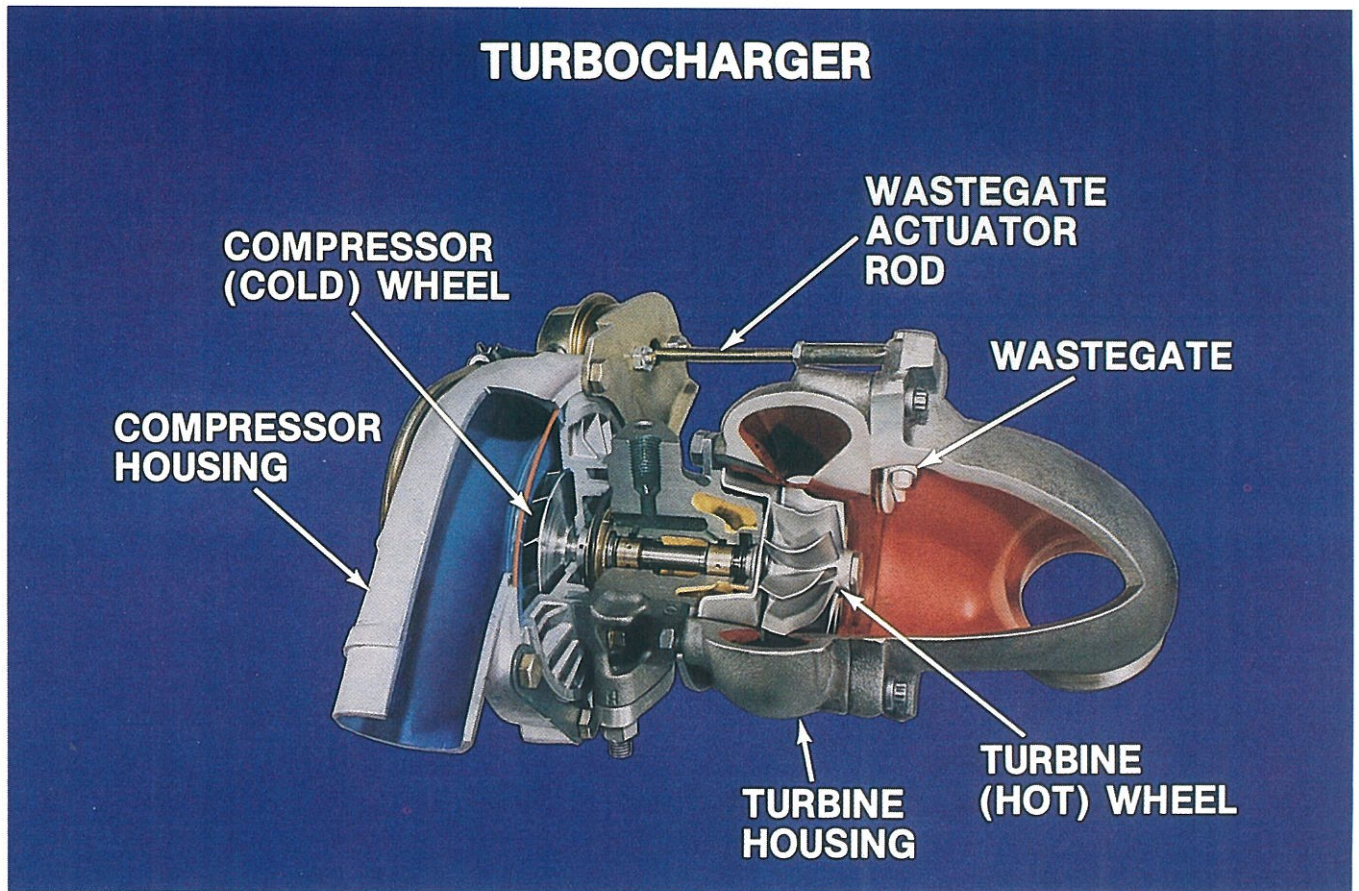

8

LEGEND

- DARK BLUE — COMPRESSED AIR
- DARK RED — EXHAUST INLET
- LIGHT RED — EXHAUST OUTLET
- WHITE — WASTEGATE

TURBOCHARGER

TURBOCHARGER LUBRICATION

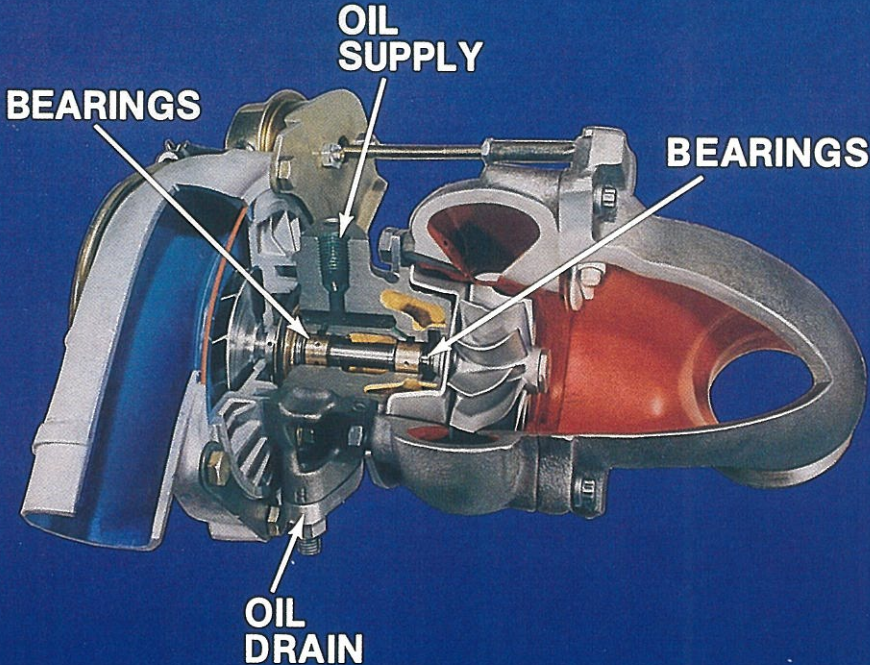

9

LEGEND

- GREEN — OIL SUPPLY
- YELLOW — RETURN OIL

7.3L IDI TURBOCHARGED DIESEL ENGINE

POWER CURVE COMPARISON

The 7.3L IDI Turbocharged Diesel Engine will consistently deliver 190 hp at 3000 rpm rated speed up to elevations of 10,000 feet.

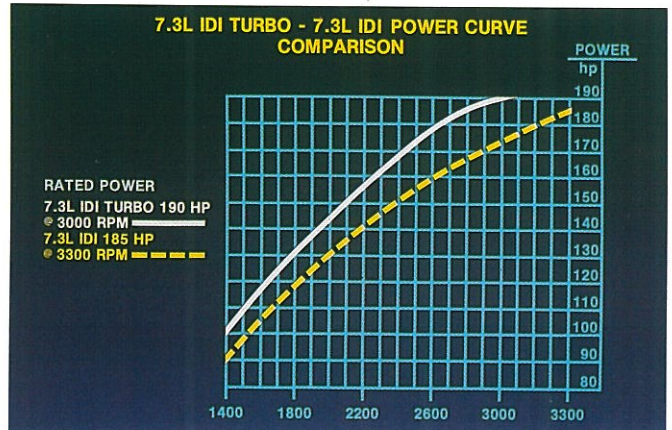

10

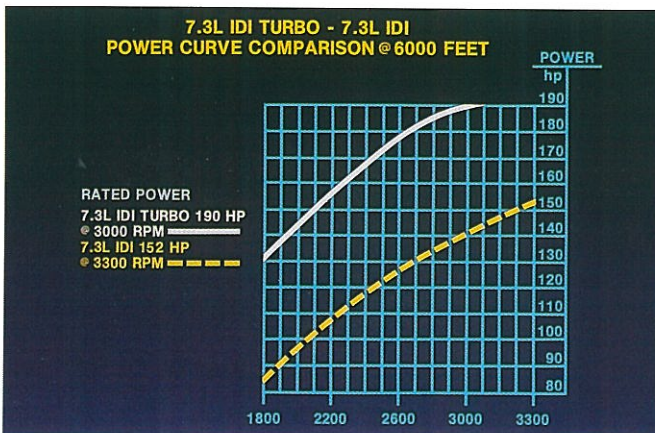

11

- A natural aspirated engine suffers a 3% loss of power per 1,000 feet of elevation above sea level
- A 185 hp engine at 6,000 feet has a 33 hp loss of power
- Some engine manufacturers also advertise a loss of power for every 1,000 feet of elevation above 5,000 feet on their turbocharged engines

TORQUE CURVE COMPARISON

The 7.3L IDI Turbocharged Diesel Engine produces a peak torque of 388 lb./ft. at 1400 R.P.M. compared to the 7.3 naturally aspirated's 338 lb./ft. on 1988-1992 engines and 358 lb./ft. on 1992½ engines.

- The 7.3L IDI Turbocharged Diesel Engine provides a significant increase in performance, altitude compensation and torque capability without sacrificing reliability of the drive train components.



12

7.3L IDI TURBOCHARGED DIESEL ENGINE SPECIFICATIONS

7.3L IDI TURBOCHARGED DIESEL ENGINE SPECIFICATIONS

ENGINE TYPE	DIESEL, 4-CYCLE
CONFIGURATION	OHV V8
DISPLACEMENT	444 cu. in.
BORE AND STROKE	4.11 x 4.18 in.
COMPRESSION RATIO	21.5:1
ASPIRATION	TURBOCHARGED
RATED POWER @ RPM	190 @ 3000
PEAK TORQUE @ RPM	385 @ 1400
ROTATION, FACING FLYWHEEL	COUNTERCLOCKWISE
COMBUSTION SYSTEM	SWIRL CHAMBER
TOTAL ENGINE WEIGHT (DRY)	900 LB.
WATER FLOW @ 3000 RPM	79 gpm
FAN-TO-CRANK-RATIO	1.1:1
HEAT REJECTION	47 BTU/HPmin
AIR FLOW @ 3000 RPM	430 cfm
EXHAUST FLOW	1250 cfm
COOLING-SYSTEM CAPACITY (ENGINE ONLY)	10 U.S. QUARTS
LUBRICATING-SYSTEM CAPACITY (INCLUDING FILTER)	10 U.S. QUARTS

13

The 7.3L IDI Turbocharged Diesel Engine is a four-cycle 90 degree block design with pushrod operated overhead valves. The engine has a displacement of 7.3 liters (444 cubic inches). 7.3L IDI Turbocharged Diesel Engine specifications are provided in Figure 9.

ENGINE TYPE	DIESEL, 4-CYCLE
CONFIGURATION	OHV V8
DISPLACEMENT	444 cu. in.
BORE AND STROKE	4.11 x 4.18 in.
COMPRESSION RATIO	21.5:1
ASPIRATION	TURBOCHARGED
RATED POWER @ RPM	190 @ 3000
PEAK TORQUE @ RPM	385 @ 1400
ROTATION, FACING FLYWHEEL	COUNTERCLOCKWISE
COMBUSTION SYSTEM	SWIRL CHAMBER
TOTAL ENGINE WEIGHT (DRY)	900 LB.
WATER FLOW @ 3000 RPM	79 gpm
FAN-TO-CRANK-RATIO	1.1:1
HEAT REJECTION	47 BTU/HP MIN
AIR FLOW @ 3000 RPM	430 cfm
EXHAUST FLOW	1250 cfm
COOLING-SYSTEM CAPACITY (ENGINE ONLY)	10 U.S. QUARTS
LUBRICATING-SYSTEM CAPACITY (INCLUDING FILTER)	10 U.S. QUARTS

7.3L IDI TURBOCHARGED DIESEL ENGINE PHYSICAL IDENTIFICATION

ENGINE SERIAL NUMBER

The 7.3L IDI Turbocharged Diesel Engine can be identified by the following:

- Engine S/N
- Calibration Label
- Emissions Label
- External Features

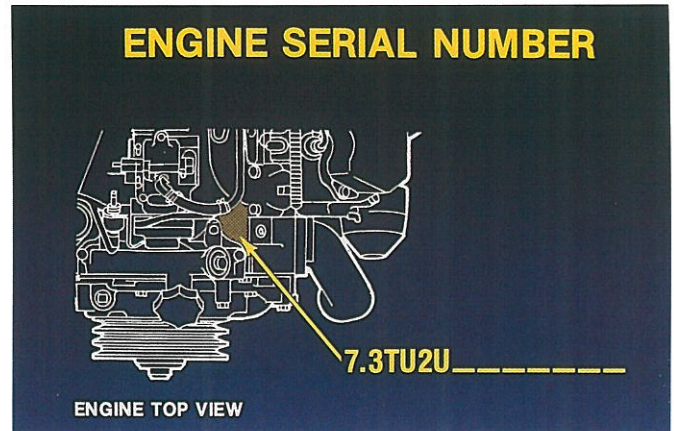

14

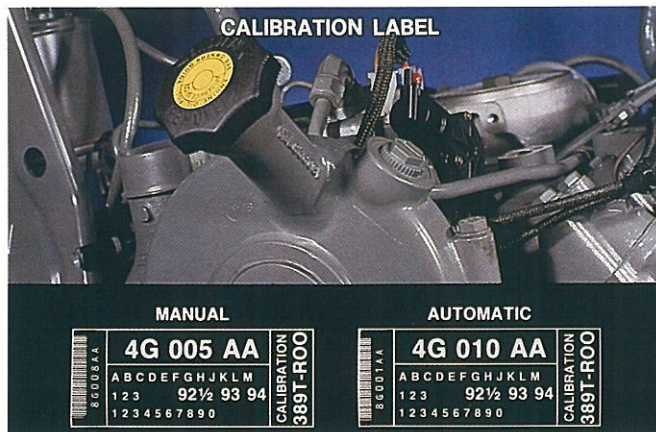

15

CALIBRATION LABEL

The calibration label located on the injection pump gear tower provides easy identification of 7.3L IDI Turbocharged Diesel Engines. The code is as listed.

- 389T-R00

EMISSIONS LABEL

The emissions label located on the left valve cover provides identification of the 7.3L IDI Turbocharged Diesel Engine. The engine model is identified as listed.

- Turbocharger Model AT190



16

EXTERNAL FEATURES



17

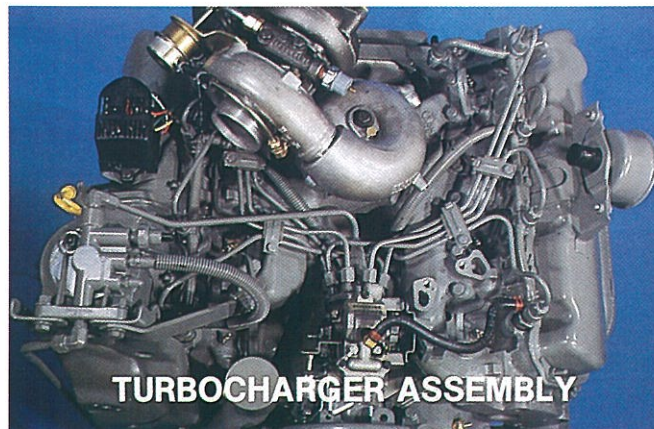

18

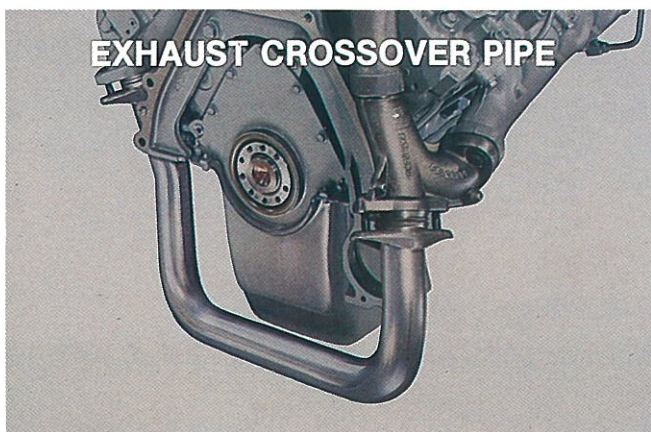

19

Figures 17, 18 & 19 identify external features of the 7.3L IDI Turbocharged Diesel Engine. Included are the air cleaner assembly, turbocharger assembly and crossover pipe.

TURBOCHARGER PACKAGE



20

The turbocharger package features a Garrett Turbocharger matched to the exhaust gas flow of the engine and features:

- A special "Y" collector to direct exhaust gas flow to the turbocharger
- An exhaust inlet casting to the turbocharger to direct exhaust gases to drive the turbine wheel
- A waste gate to protect the turbocharger from overspeed by modulating boost pressure
- An air chamber to direct compressed air into the intake manifold and onto the cylinders for combustion

TURBOCHARGER PACKAGE

TURBOCHARGER ASSEMBLY



GARRETT T-3

21

The Garrett T-3 turbocharger allows the engine to operate up to 10,000 ft. elevation with no loss of power. Intake manifold pressure (boost) will be modulated through the use of a wastegate.

The name plate on the turbocharger identifies the part number and component serial number.

TURBOCHARGER ID PLATE



22

TURBOCHARGER ID PLATES



PRODUCTION OR NEW SERVICE PLATE



FACTORY OVERHAULED PLATE

23

The part number of the turbocharger should always be verified whenever replacement is performed by comparing part numbers on the name plates.

TURBOCHARGER PACKAGE

A/R RATIO

Exhaust turbine A/R ratios determine turbine wheel speed.

Small A/R ratios—high turbine wheel speed.

Large A/R ratios—low turbine wheel speed.

A/R RATIO IS A COMPARISON OF THE TURBINE NOZZLE CROSS SECTION AND THE RADIUS OF THE TURBINE GAS FLOW

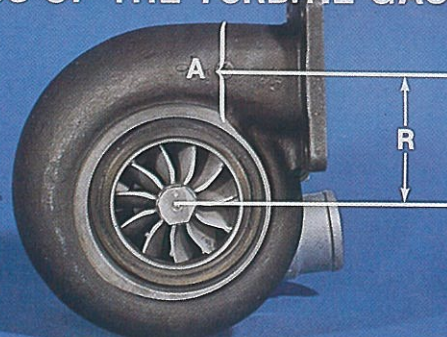

- SMALL A/R RATIOS-HIGH TURBINE SPEEDS
- LARGE A/R RATIO-LOW TURBINE SPEEDS

24



A/R RATIO

The .82 A/R ratio allows high turbine wheel speeds at low engine speeds.

This A/R ratio provides the best balance and match of performance at all speeds.

The A/R ratio should always be verified when a turbocharger is replaced.

25

TURBOCHARGER PACKAGE



26

CROSSOVER PIPE

The crossover pipe is a single piece, mandrel bent to decrease exhaust restriction and to provide adequate clearance between the oil pan, flywheel cover and transmission mounting bolts.

“Y” COLLECTOR

The “Y” collector features a special design which optimizes exhaust pulsations and flow characteristics to the turbocharger. This feature also prolongs turbocharger life.



27

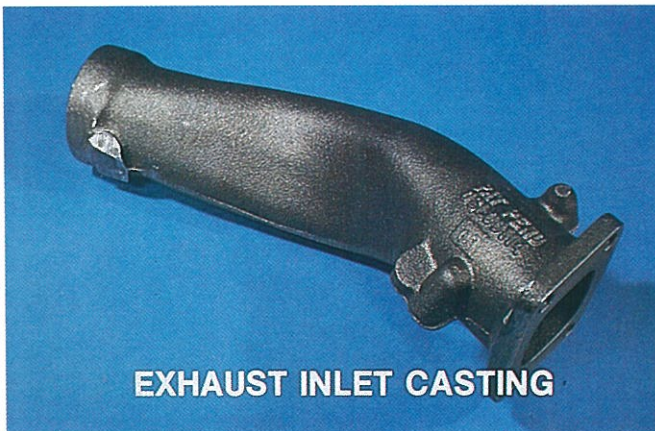

28

EXHAUST INLET CASTING

The turbocharger exhaust inlet casting's design directs the exhaust gases entering the turbine for optimum performance of the turbine wheel.

TURBOCHARGER PACKAGE

WASTEGATE

The wastegate regulates maximum speed of the turbocharger by allowing excess exhaust gases to bypass the turbine housing and be directed into the exhaust stream to atmosphere.



30

MARMON CLAMP

The exhaust outlet and exhaust downpipe are connected together with a Marmon clamp. Marmon type clamps provide superior sealing of exhaust gases versus slip joint type connection.

16

WASTEGATE

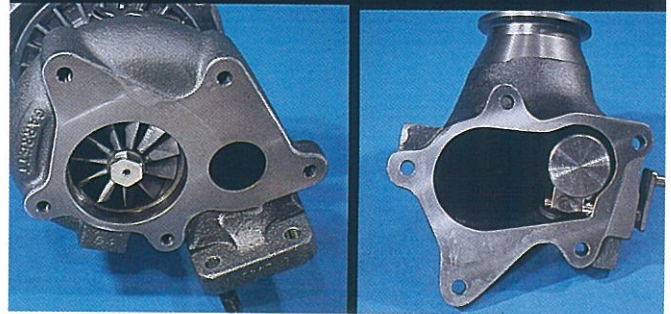

29

WASTEGATE ACTUATOR

The wastegate actuator is a spring loaded diaphragm acted on by manifold pressure. Manifold pressure assists in opening the wastegate, spring pressure closes the wastegate. Exhaust pressure in the turbine housing also assists in opening the wastegate.

- Wastegate actuators obtained through service parts will have to be adjusted should replacement be required.

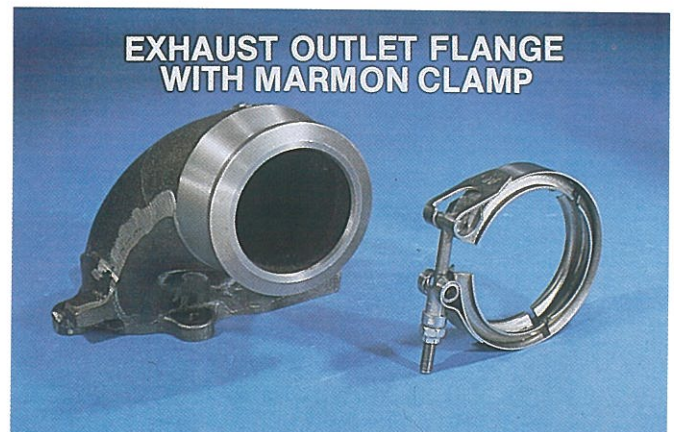

31

TURBOCHARGER PACKAGE



32

PEDESTAL

The turbocharger mounting/oil drain pedestal attaches to the rear of the intake manifold. This design eliminates the need for an external oil drain line.

PEDESTAL

The opening in the intake manifold and the oil drain opening at the compressor housing are sealed by Viton "O" rings that fit into the pedestal.

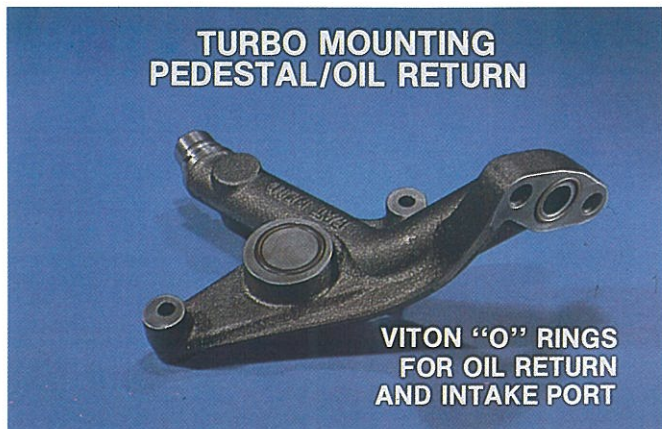

33



34

PEDESTAL

A special grommet secured in the valley pan seals the return oil drain.

NOTE: **DO NOT** attempt to use old CDR grommet to seal turbo oil drain.

TURBOCHARGER PACKAGE

AIR CHAMBER

The air chamber is designed to provide the optimum swirl for equal air distribution to all cylinders.

- A conventional type, Viton "O" Ring seals the air chamber to the compressor housing
- The air chamber is sealed to the intake manifold by a square cut "O" ring seal
- A copper seal washer is also used on the hold down bolt

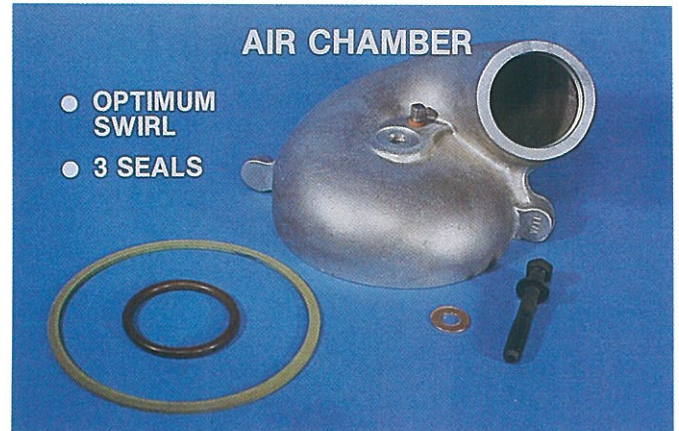

35

TURBOCHARGER OIL MANIFOLD



- TURBOCHARGER OIL SUPPLY
- ENGINE OIL PRESSURE SENDER

36

OIL MANIFOLD

An oil manifold is located on the oil inlet side of the turbocharger center section. This manifold features two ports for attaching the following:

- Turbocharger oil supply line
- Engine oil pressure sender

TURBOCHARGER OIL SUPPLY

The turbocharger is supplied lube oil from the oil galley at the former oil pressure sender location.

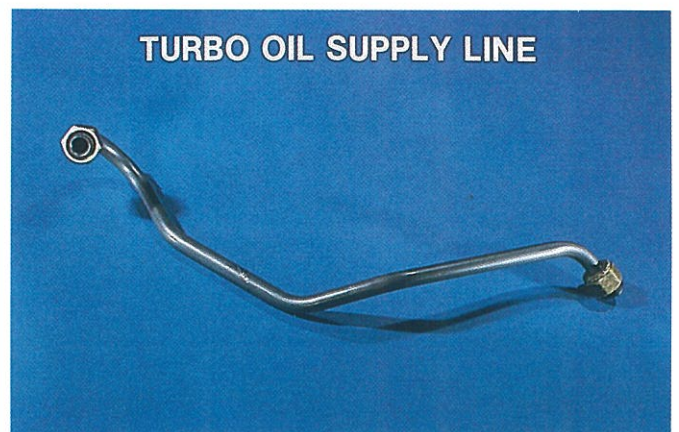

37

TURBOCHARGER PACKAGE



38

TURBOCHARGER OIL LINE

A formed steel line is used to supply oil to the turbocharger center section.

HEAT SHIELDING

HEAT SHIELDING

Heat shields made with fiberglass, encased in stainless steel, over the turbine housing and exhaust inlet casting are also part of the turbocharger package.



39

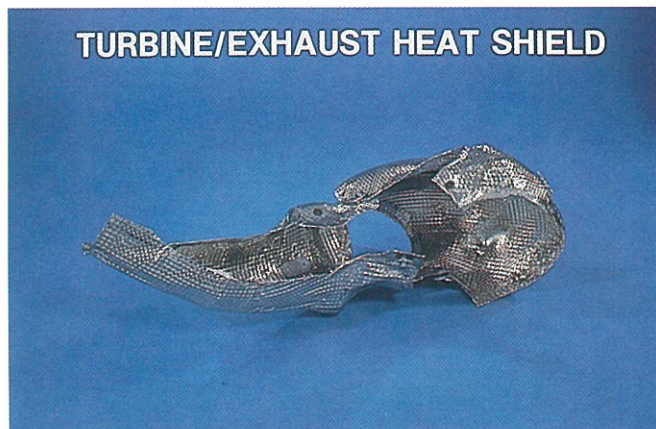

40

HEAT SHIELDING

The heat shielding is formed to the exterior shape of the area which it covers.

The heat shielding is secured to the turbocharger by one (1) bolt in the exhaust inlet casting, band clamps and pins with clips.

Heat shielding is on the crossover pipe and rear of the left exhaust manifold.

AIR CLEANER ASSEMBLY

AIR CLEANER ASSEMBLY

The air cleaner assembly is positioned on the engine over the left bank injection lines. The lower housing is bolted to the intake manifold. The upper housing is secured to the lower housing with studs and nuts. Both housings are cast aluminum.

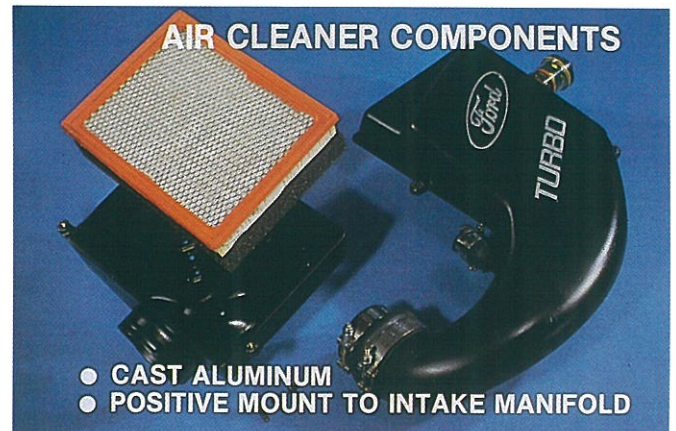

41

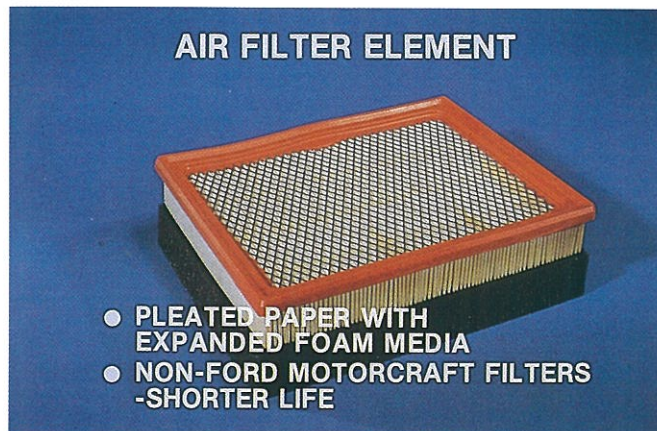

42

AIR CLEANER ELEMENT

The air cleaner element is a pleated paper panel type and features expanded foam filter media attached to the bottom of the paper. This filter has specifically been designed to provide adequate filter life.

Note: Non-Ford Motorcraft replacement filters may result in significantly shortened filter life and dirt ingestion.

FILTER MINDER

A filter minder gauge is mounted in the "clean air" side of the upper housing. This allows the user to monitor air cleaner element condition as it indicates when the element should be changed. The filter minder measures air flow restriction in the air filter and is calibrated in inches of water.



43

VALVE COVERS



LEFT VALVE COVER

The left valve cover on the 7.3L IDI Turbocharged Diesel Engine has the Crankcase Depression Regulator (CDR) valve mounted on it. A formed reinforced rubber hose connects it to the air cleaner upper housing by clamps.

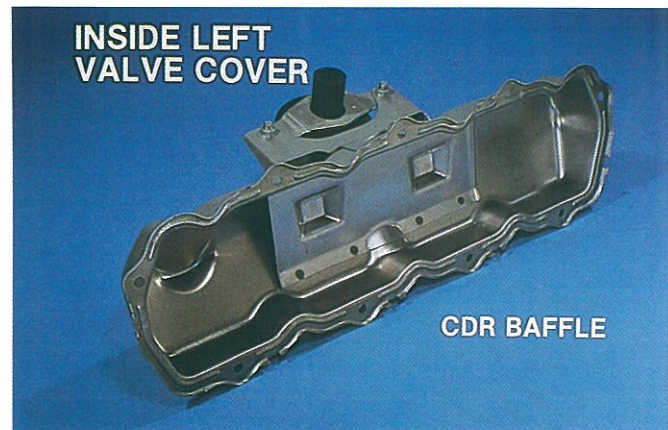

LEFT VALVE COVER

The left valve cover is baffled to prevent excessive oil carry over from valve train oil splash.

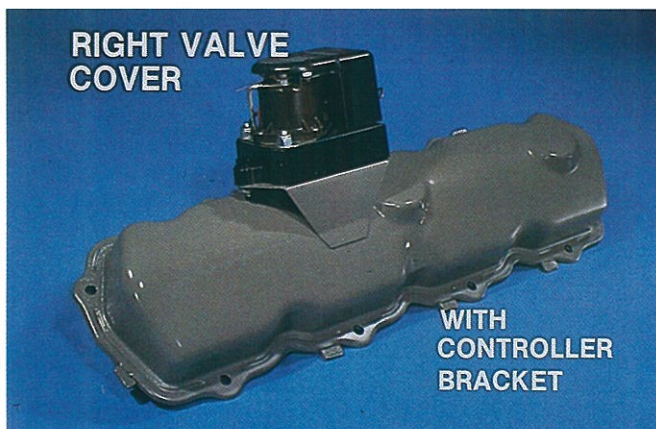

RIGHT VALVE COVER

The right valve cover has a bracket welded on it for glow plug controller mounting.

ENGINE WIRING HARNESS

ENGINE HARNESS

The turbo engine harness is made to conform to the relocated glow plug controller and is routed side to side at the front of the engine.

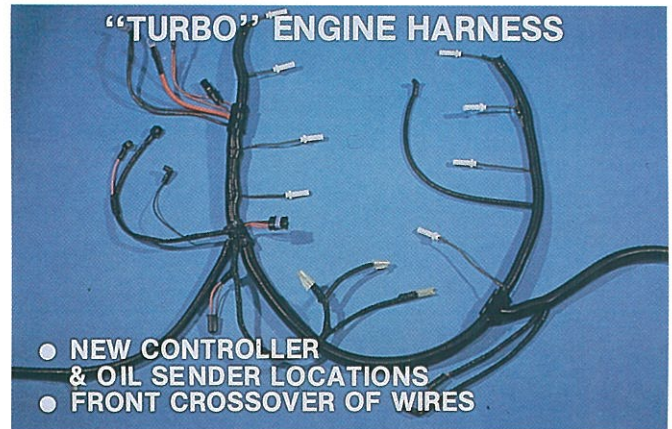

47

DESIGN MODIFICATIONS

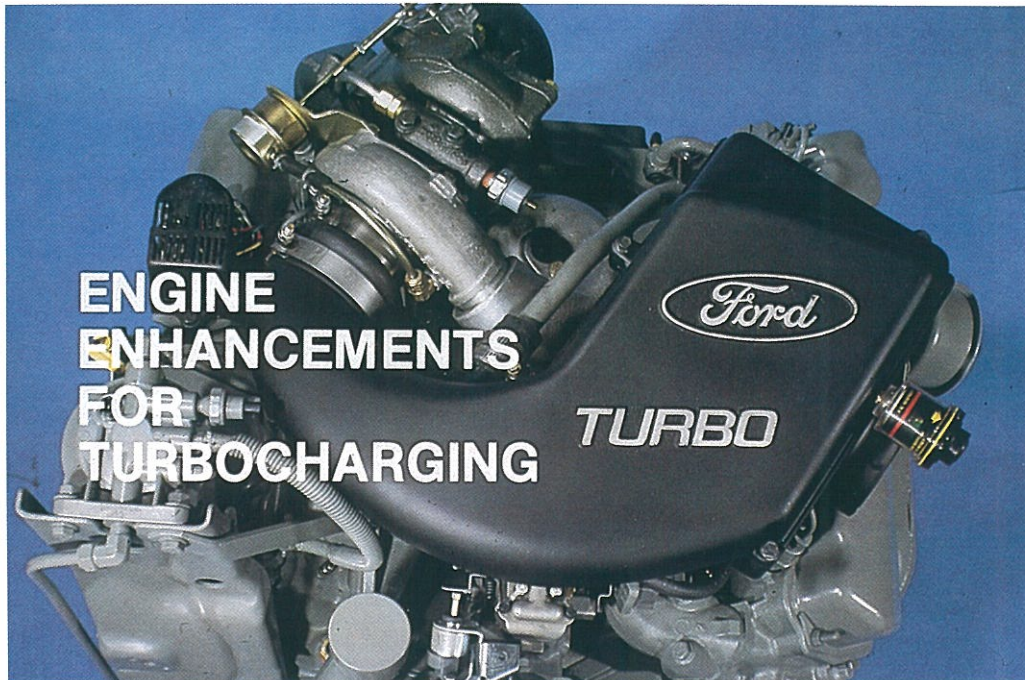

48

Design modifications have been incorporated into the internal engine components to withstand the pressures of turbocharging without compromising engine reliability or durability. Modifications referred to include:

- Cylinder Head Gasket
- Connecting Rod
- Piston
- Piston Pin
- Rings
- Exhaust Valve

Although not internal, modifications have also been made to:

- Oil Cooler Bundle
- Flywheel
- Vibration Damper
- Fuel Injection Pump
- Injection Nozzle

INTERNAL PARTS CHANGES

HEAD GASKET

The head gasket on the 7.3L IDI Turbocharged Diesel Engine has a heavier fire ring and armor wrap to withstand higher firing pressures and combustion temperature.

The turbocharged head gasket can be identified by the notch in the gasket on the bottom (exhaust manifold) side.

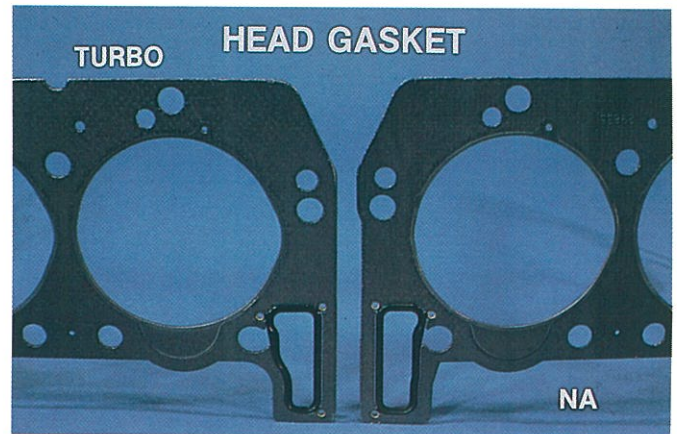

49



50

TURBOCHARGED POWER CYLINDER COMPONENTS

Significant design changes have been made to the power cylinder components of the 7.3L IDI Turbocharged Diesel Engine.

CONNECTING ROD

To provide additional strength for the increased horsepower output, the connecting rod has a large wrist pin bore and large wrist pin bushing. The pin bore diameter has been increased from 1.1108" to 1.3086", a 17% increase.



51

INTERNAL PARTS CHANGES

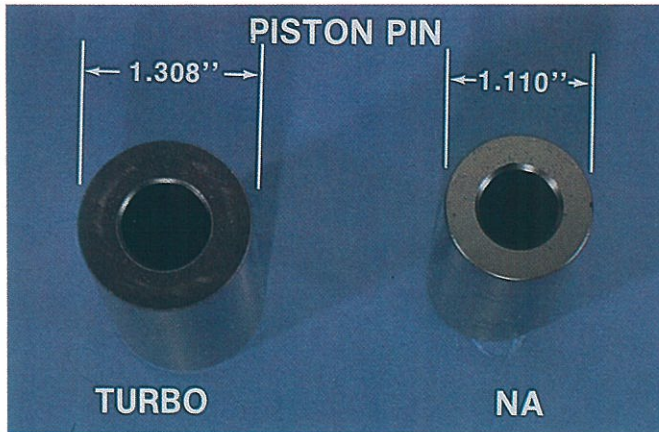

52

ANODIZED PISTON HEAD

The piston head for the 7.3L IDI Turbocharged Diesel Engine is anodized. Anodizing is an electrostatic coating process by which aluminum oxide is applied to the head of the piston. The anodized surface is more resistant to cracks caused by the increased firing pressures and combustion temperatures associated with turbocharging.

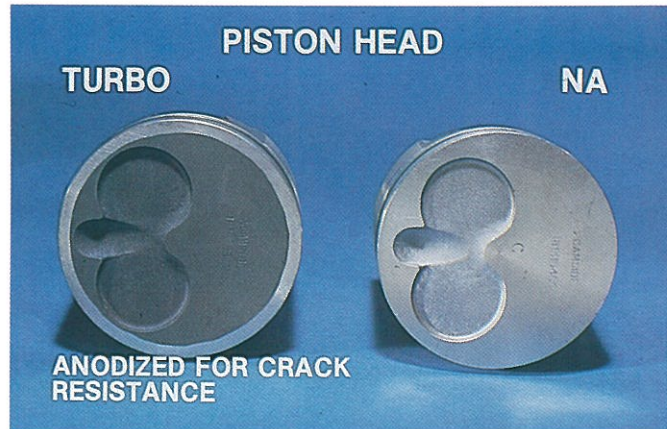

53



54

PISTON RINGS KEYSTONE DESIGN

The top and intermediate ring on the 7.3L IDI Turbocharged Diesel Engine are keystone design. Top ring is 15° Second ring is 6° Oil control ring is rectangular.

Keystone rings are a premium heavy duty diesel feature that complements turbocharging which improves ring life and decreases the potential for ring sticking.

INTERNAL PARTS CHANGES

RING GROOVE MEASUREMENT

The Keystone top ring groove wear is measured by inserting specific gauge pins in the ring groove and measuring across the pins with an outside micrometer.

KEYSTONE RING GROOVE WEAR MEASUREMENT



TOP RING GROOVE
GAUGE PIN DIAMETER .115 in

55



TOP RING GROOVE MEASUREMENT

UPPER LIMIT 4.130"
LOWER LIMIT 4.097"

56

RING GROOVE MEASUREMENT

The top ring groove is measured over 0.115" gauge pins.

Upper limit—4.130"

Lower limit—4.097"

The gauge pins can be ordered from O.T.C. Tool #ZTSE 3020-1.

RING GROOVE MEASUREMENT

The intermediate Keystone top ring groove wear is measured by inserting specific gauge pins in the ring groove and measuring across the pins with an outside micrometer.

KEYSTONE RING GROOVE MEASUREMENT

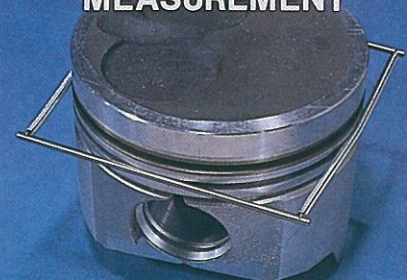

INTERMEDIATE RING GROOVE
GAUGE PIN DIAMETER .098 in

57

INTERNAL PARTS CHANGES

INTERMEDIATE RING GROOVE MEASUREMENT

UPPER LIMIT 4.160"
LOWER LIMIT 4.135"



58

RING GROOVE MEASUREMENT

The intermediate ring groove is measured over 0.098" gauge pins.
Upper limit 4.160"
Lower limit 4.135"

The gauge pins can be ordered from O.T.C. Tool #ZTSE 3020-3.

EXHAUST VALVE

The exhaust valve used in the 7.3L IDI Turbocharged Diesel Engine is made of Inconel alloy and the valve stem is full chrome plated. Inconel alloy provides greater corrosion resistance and fatigue strength at the higher temperatures of the turbocharged engine. The turbocharger exhaust valve can be identified by the dimple and part number on the head of the valve.

This valve has same 37.5° face angle.

EXHAUST VALVES

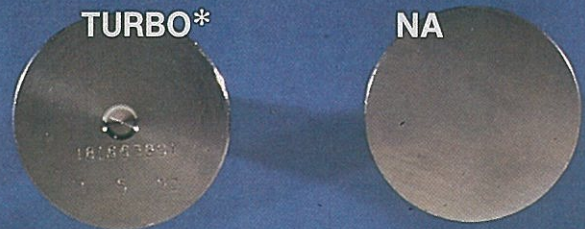

*INCONEL ALLOY

- IMPROVES FATIGUE STRENGTH
- GREATER CORROSION RESISTANCE

59

EXTERNAL MODIFICATIONS

OIL COOLER BUNDLE



60

OIL COOLER BUNDLE

The oil cooler bundle on the 7.3L IDI Turbocharged Diesel Engine has increased fin density for additional heat dissipation.

30 Fins Per Inch on the Turbocharged version versus 24 Fins per inch on the N.A. Engine.

27

EXTERNAL MODIFICATIONS

FLYWHEEL

Heavier engine components change the engine balance and require use of "Turbocharger" specific flywheels for manual and automatic transmissions.

Manual F3TZ6375A

Auto 1816637C1

These changes are not discernible other than by the part number.



61



62

VIBRATION DAMPER

Changes in engine balance require a different value of harmonic balance of the vibration damper.

Turbocharged P/N 1816624C1

N/A P/N 1809117C1

Physical differences in the vibration damper are illustrated.

NOTE: vibration dampers cannot be interchanged.

FUEL INJECTION PUMP

The external appearance of the Stanadyne Model DB2 injection pump is unchanged.

- Calibration of the pump complements turbocharging and is necessary to attain desired engine performance and meet emissions standards.

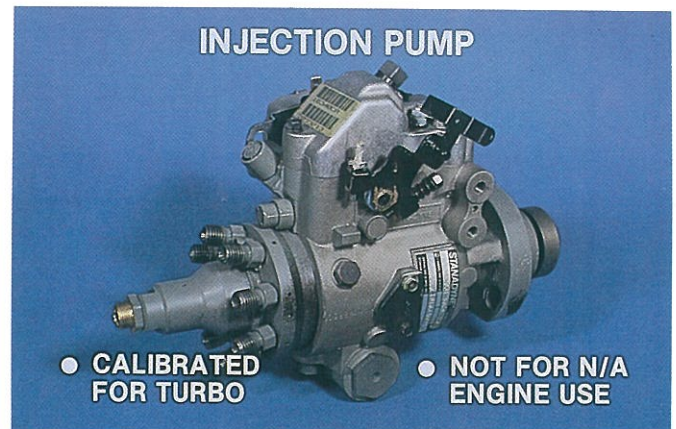

63

EXTERNAL MODIFICATIONS

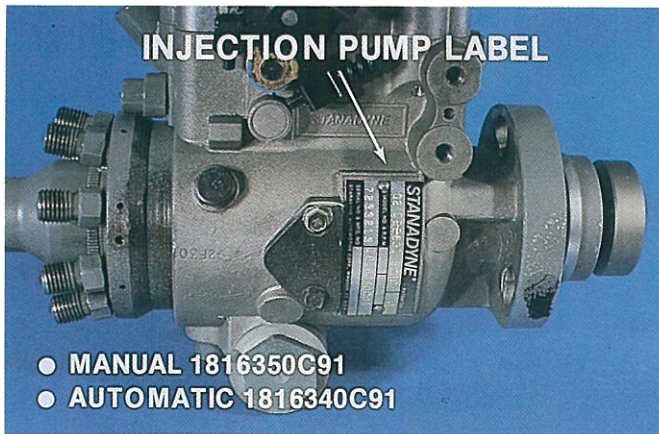

64

FUEL INJECTION NOZZLE

The fuel injection nozzle used on the turbo engine is a "G" code. The visual appearance is the same as the N.A. engine's "E" code. The flow characteristic of the nozzle is tailored for the turbocharged engine.



65

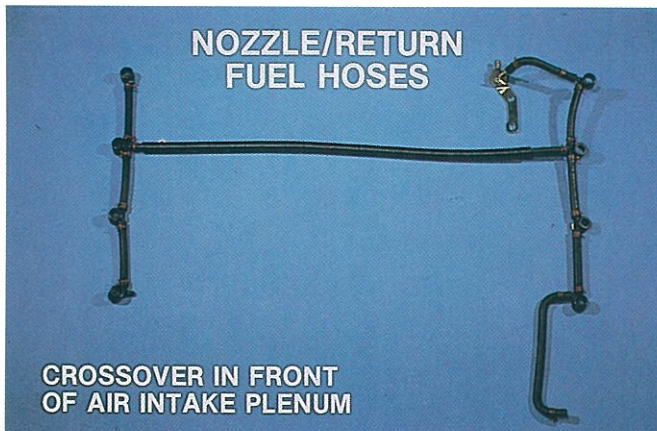

66

FUEL INJECTION PUMP

The injection pump I.D. tag shows the Navistar part number. Always verify part number should the pump be changed.

- Do not use this pump on natural aspirated engines

FUEL RETURN LINE

The nozzle return fuel line crossover has been relocated from the rear of the engine to the front of the air intake plenum to protect the line from the turbocharger exhaust system heat.

TURBOCHARGED ENGINE DIAGNOSTICS

67

68

DIAGNOSTIC FORMS

We will continue to evaluate engine performance through the use of a diagnostic form, with procedures expanded for testing of boost and the wastegate actuator.

69

- BOOST PRESSURE TEST
- WASTEGATE ACTUATOR TEST
- CRANKCASE PRESSURE TEST
- TRANSFER PUMP PRESSURE TEST
- INJECTION PUMP TIMING

DIAGNOSTIC CHANGES

Engine performance diagnostics have changed on the turbocharged 7.3

- Addition of boost test
- Addition of wastegate actuator test
- Safety concerns during transfer pump test
- Revised injection nozzle test specification
- Air cleaner restriction

BOOST TEST

Boost test has been added to the diagnostic form for the turbocharged 7.3.

TO 0-15 PSI PRESSURE GAUGE

4. TURBOCHARGER BOOST—See illustration—Reverse Side
Remove air cleaner assembly and connect 0-15 Pressure gauge to the boost test port on the air chamber. Re-install the air cleaner.

- With automatic transmission perform a torque converter stall test (1900-2100) RPM. Observe PSI reading.
- With manual transmission in 2nd gear, accelerate from 1200 to 2300 RPM. Observe PSI reading.

INSTRUMENT	GUIDELINE DATA	1ST CHECK	2ND CHECK
0-15 psi Gauge	5 psi Boost Minimum		

NOTE: If boost is within limits performance is acceptable

● If boost is low, go to test 5

70

TURBOCHARGED ENGINE DIAGNOSTICS



71

BOOST TEST

Remove pipe plug, install adapter and hose connecting to gauge bar to obtain boost measurement.



72



73

BOOST TEST

Re-install air cleaner assembly.

DO NOT PERFORM BOOST TEST WITH AIR CLEANER REMOVED.

TURBOCHARGED ENGINE DIAGNOSTICS

BOOST TEST

Position gauge bar set in the cab of the truck where gauge reading can be observed.

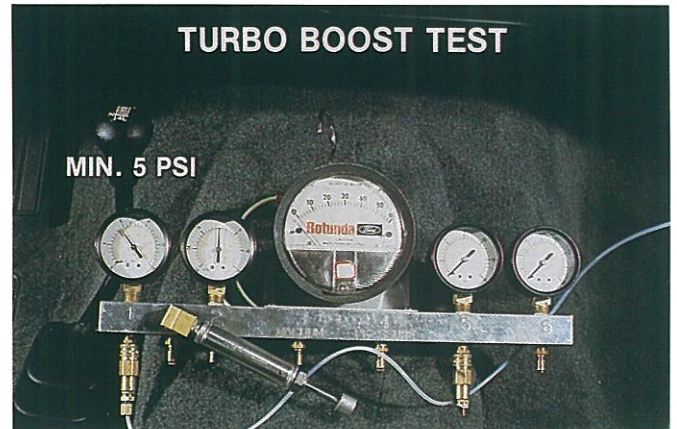

74

TURBOCHARGER BOOST TEST CRITERIA

- AUTOMATIC TRANSMISSION CONVERTER STALL 1680/2100 RPM
- MANUAL TRANSMISSION ACCELERATE FROM 1200/2800 RPM IN SECOND GEAR

5 PSI BOOST SHOULD BE OBSERVED

NOTE: IF ENGINE MAKES BOOST, POWER IS OK

75

BOOST TEST

On units with automatic transmission, perform a converter stall test (1680-2100 rpm). A 5 psi min. should be observed. On units with manual transmission and in second gear at 1200 rpm accelerate to 2800 rpm, 5 psi min. should be observed.

- Stall speed listed is for E40D transmission only

WASTEGATE ACTUATOR TEST

Wastegate Actuator Test has been added to the diagnostic test form.

5. WASTEGATE ACTUATOR CONDITION—See *Illustration—Reverse Side*
 Connect 0-30 psi gauge and hand pump to actuator. Apply pressure to actuator with hand pump. Actuator rod should begin to move at 12-15 psi. Full actuator rod travel should occur at 20-22 psi. Observe pressure gauge for 30 seconds after 20-22 psi has been attained. No decrease in pressure should occur.

INSTRUMENT	GUIDELINE DATA	1ST CHECK		2ND CHECK	
0-30 PSI GAUGE	A. ROD TRAVEL START AT 12-15 PSI				
	B. FULL ROD TRAVEL AT 20-22 PSI				
	C. NO DECAY OF APPLIED PRESSURE				

- If actuator rod fails to move, remove rod from wastegate and check wastegate for freedom of movement.
- If wastegate is free, replace actuator.
- If wastegate will not move, free up wastegate or replace housing containing wastegate.

76

TURBOCHARGED ENGINE DIAGNOSTICS



77

WASTEGATE ACTUATOR TEST

Connect hand pump and 0-30 psi gauge to actuator.

WASTEGATE ACTUATOR TEST

Start of rod travel movement should be observed at 12-15 psi applied via hand pressure pump.



78

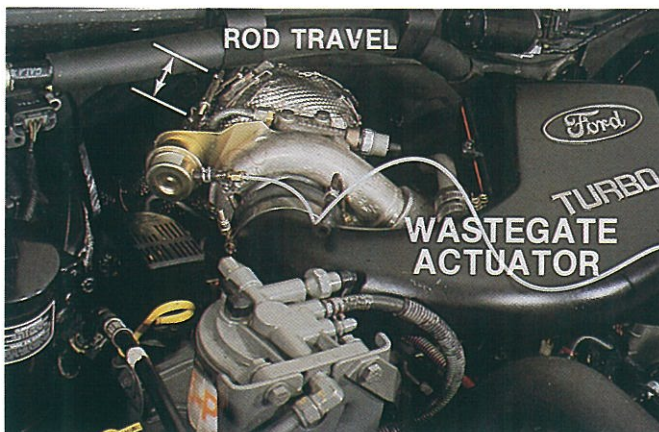

79

WASTEGATE ACTUATOR TEST

No further rod travel should be observed after 20-22 psi has been applied via hand pressure pump.

Total rod movement is less than .500"

TURBOCHARGED ENGINE DIAGNOSTICS

WASTEGATE ACTUATOR TEST

The 20-22 psi should be maintained for 30 seconds with no decay. This verifies diaphragm condition.

If pressure decay occurs, replace actuator.



80

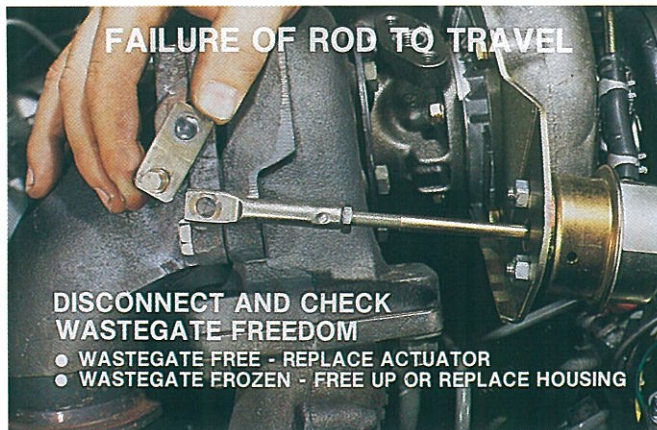

81

WASTEGATE ACTUATOR TEST

If wastegate does not move, remove actuator rod from wastegate and check wastegate for freedom of movement. If wastegate moves freely, replace actuator.

If wastegate does not move, spray shaft and lever area with WD40 or equivalent.

If wastegate cannot be freed up, the wastegate housing will have to be removed for repair or replacement.

AIR FILTER RESTRICTION TEST

With the increased air flow requirements of the turbocharged engine, air filter restriction becomes more important to the actual performance of the vehicle.

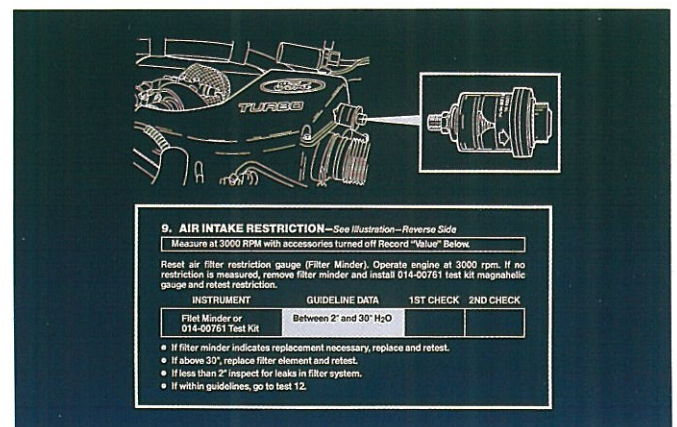

82

TURBOCHARGED ENGINE DIAGNOSTICS



83

AIR FILTER RESTRICTION TEST

Change air filter element when restriction gauge indicates a fully deployed flag or when 30 inches of water restriction is measured with a magnahelic gauge.

INJECTION PUMP TIMING TEST

11. INJECTION PUMP TIMING—See illustration—Reverse Side

Attach the clamp to the line pressure sensor on the No. 1 injection nozzle for F-Series, and connect the dynamic timing meter. Dial .20" offset on the meter. Disconnect solid start advance solenoid connector from the solenoid terminal. Maintain 2000 RPM with engine at operating temperature and record dynamic timing in Box A. Apply battery voltage to solenoid terminal, maintain 2000 RPM and record dynamic timing in Box B. (Record "Values" Below).

INSTRUMENT	GUIDELINE DATA	1ST CHECK		2ND CHECK	
		(° BTDC)	(° BTDC)	(° BTDC)	(° BTDC)
078-00200 Dynamic Timing Meter and 078-00201 Adapter	A. 8° ± 2° BTDC @ 2000 RPM. B. Check with power to advance solenoid				

- Advance Timing Check (B) should be 1" (min.) more advanced than Timing Check (A).
- If B is less than 1.0" advance from A, replace fuel injection pump.

84

INJECTION TIMING

- UNCHANGED
- 8° ± 2° @ 2000 RPM

85

INJECTION PUMP TIMING

Injection pump dynamic timing on the 7.3L IDI Turbocharged Diesel Engine is the same as the 7.3 N.A. engine 8° ± 2° B.T.D.C. @ 2000 rpm with the Rotunda timing meter 078-00200. Timing is by the line pulse method with Rotunda adapter 078-00201.

TURBOCHARGED ENGINE DIAGNOSTICS

INJECTION PUMP TRANSFER PRESSURE TEST



12. CHECK INJECTION PUMP TRANSFER PRESSURE—
See Illustration—Reverse Side

SAFETY PRECAUTION
A COMPRESSOR INLET SAFETY GUARD MUST BE INSTALLED WHEN ENGINE IS RUNNING WITHOUT AIR CLEANER ATTACHED.

NOTE: Perform only if 1st Timing Check (Step 11) was not within specification.

Measure at 3000 RPM with accessories turned off. Record "Value" Below.

INSTRUMENT	GUIDELINE DATA	1ST CHECK	2ND CHECK A
* T83T 9000-A 0-160 PSI Gauge 5630 Adapter	90-120 PSI @ 3000 RPM		

* If pressure is not to specification, replace fuel injection pump. NOTE: WARRANTY CLAIMS FOR THE INJECTION PUMP WILL NOT BE ACCEPTED UNLESS ALL TAMPER RESISTANT SEALS ARE INTACT AND THE COMPLETED ENGINE PERFORMANCE CHART (VALUES RECORDED) IS SUBMITTED WITH THE RETURNED PART.

86

TRANSFER PUMP TEST

SAFETY PRECAUTION

A COMPRESSOR INLET SAFETY GUARD MUST BE INSTALLED WHEN ENGINE IS RUNNING WITHOUT AIR CLEANER ATTACHED

87

TRANSFER PRESSURE TEST

Since the air cleaner assembly must be removed to perform this test, a guard should be used on the compressor wheel opening to protect the turbocharger from object damage.

TRANSFER PRESSURE TEST

A guard from OTC P/N JDG576 can be used or a guard may be made locally.



88

TURBOCHARGED ENGINE DIAGNOSTICS

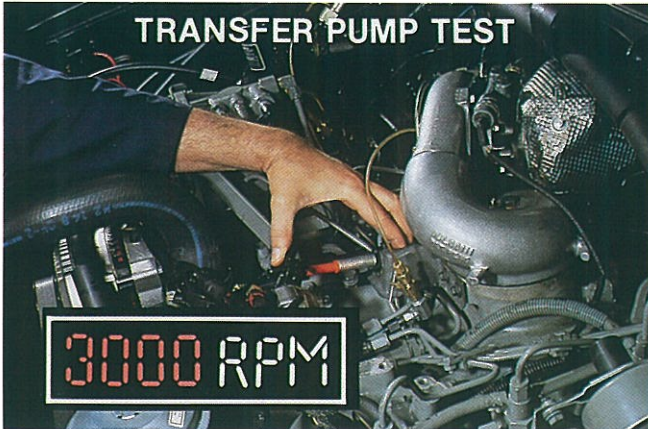

89

TRANSFER PUMP TEST

With transfer pump adapter connected to the 0-160 psi gauge, run the engine at 3000 rpm.

TRANSFER PRESSURE TEST

While the engine is at 3000 rpm, observe gauge reading. Spec. 90-120 psi.

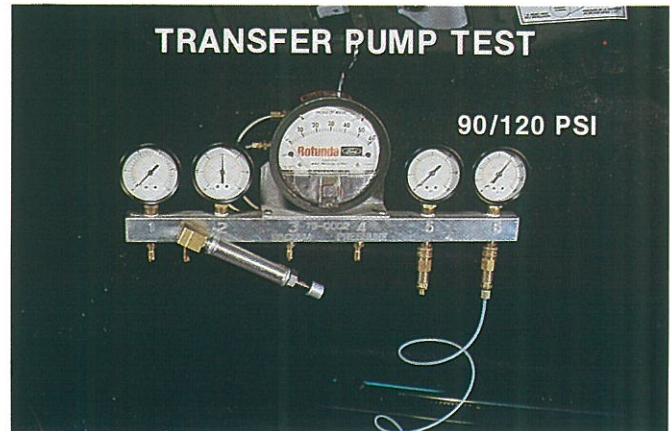

90

014-00300
NOZZLE
TESTER

INJECTION
NOZZLE

USE OTC-208629
CALIBRATING OIL ONLY

13. CHECK INJECTION LINES AND INJECTION NOZZLES
~See Illustration~ Reverse Side

NOTE: Perform only if engine is missing or running roughly.

INSTRUMENT	GUIDELINE DATA		
014-00300 Injection Nozzle Tester	Engine Calibration	389TR00	
	Code on Nozzle Body	G	Record "Values" Below
	Minimum Opening Pressure	1450 PSI	

91

NOZZLE TEST

Nozzle testing should only be performed if the engine has a cylinder miss or is running roughly.

TURBOCHARGED ENGINE DIAGNOSTICS

NOZZLE TEST

Nozzle Test Specs. New or reconditioned nozzles opening pressure is 1900 ± 75 psi.

Minimum pressure on used nozzles before replacement is 1450 psi.

NOZZLE TEST SPECIFICATIONS

NEW/RECONDITIONED

● 1900 ± 75 PSI

USED

● 1450 PSI MIN

92

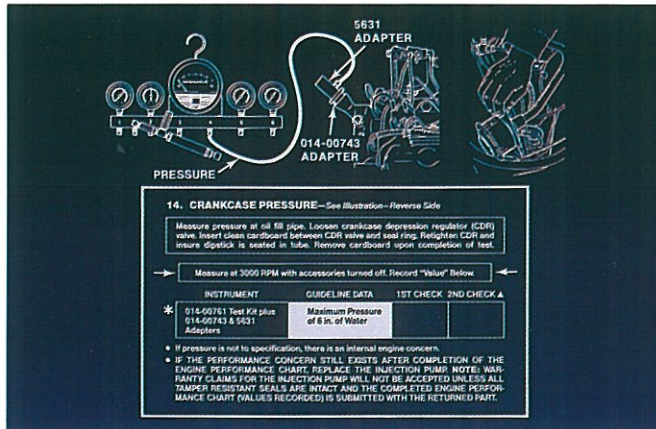

93

CRANKCASE PRESSURE TEST

The crankcase pressure test has changed due to the new location of the Crankcase Depression Regulator. Specification is unchanged.

CRANKCASE PRESSURE TEST

To perform crankcase pressure test, loosen two CDR mounting bolts.



94

TURBOCHARGED ENGINE DIAGNOSTICS

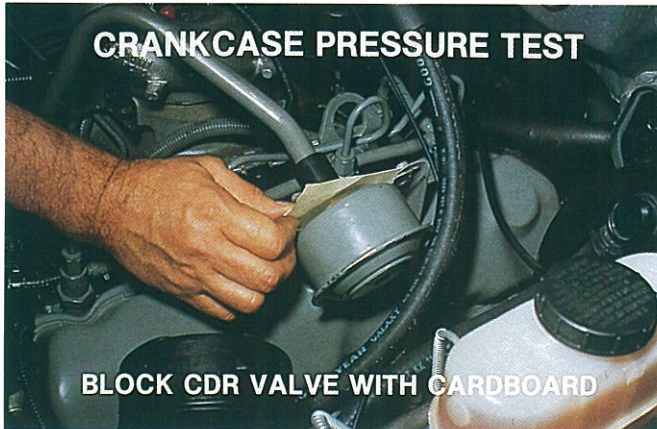

95

CRANKCASE PRESSURE TEST

Remove oil fill cap. Install orifice restrictor tool and adapter.



96

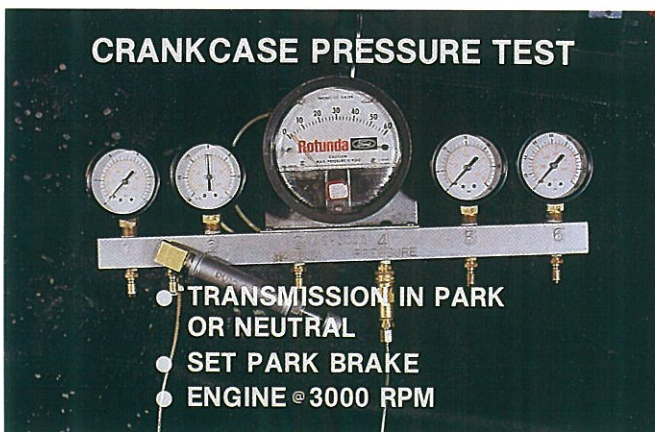

97

CRANKCASE PRESSURE TEST

With transmission in neutral (PARK) and park brake set, start engine and run engine at 3000 rpm. Observe reading on magnahelic gauge. Specification is 6 inches of water max. High crankcase pressure readings relate to power cylinder components in poor condition.

Remember to remove cardboard blocking CDR valve after completing the test.

SERVICE TIPS

SERVICE TIPS

TURBO

- REMOVAL/INSTALLATION
- COMPONENT REPLACEMENT

ACTUATOR

- REMOVAL/INSTALLATION

INJECTION PUMP

- REMOVAL/INSTALLATION

TORQUING

- MAIN BEARING CAP BOLTS
- FLYWHEEL BOLTS

98

- TURBOCHARGER ASSEMBLY REMOVAL AND RE-INSTALLATION
- TURBOCHARGER CENTER SECTION REPLACEMENT
- WASTEGATE ACTUATOR REPLACEMENT
- INJECTION PUMP REMOVAL AND REPLACEMENT
- TORQUING PROCEDURES
 - MAIN BEARING BOLTS
 - FLYWHEEL BOLT
- AIR INDUCTION PRESSURE TEST

SERVICE TIPS



99

TURBO REMOVAL

From under vehicle, remove two nuts, securing the crossover pipe flange to the left exhaust manifold.



100



101

TURBO REMOVAL

Listed are important steps to ease removal and installation of the turbocharger assembly.

TURBO REMOVAL

From under vehicle, remove two "Y" collector mounting bolts from the right exhaust manifold.

SERVICE TIPS

TURBO REMOVAL

Twist and pull down on crossover pipe to separate "Y" collector from exhaust inlet casting.

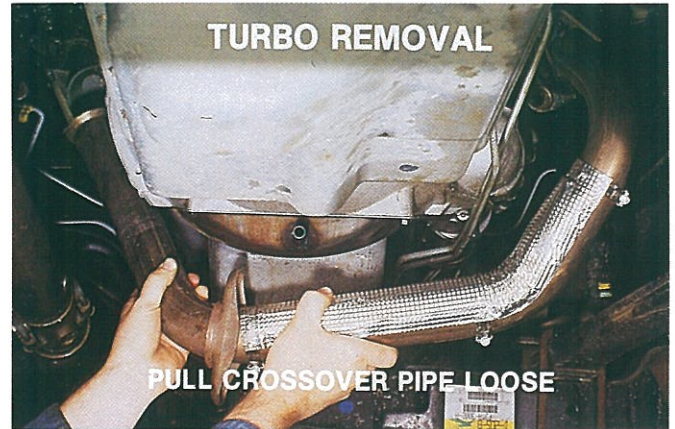

102



103

TURBO REMOVAL

Once separated, let crossover pipe rest loose under vehicle.

TURBO REMOVAL

Inside the engine compartment, after air cleaner has been removed, loosen the turbocharger's oil supply line nut at oil manifold.



104

SERVICE TIPS



105

TURBO REMOVAL

Loosen oil supply line nut at the rear of the engine.



106



107

TURBO REMOVAL

Remove oil supply line.

SERVICE TIPS

TURBO REMOVAL

Loosen Marmon clamp at exhaust outlet down pipe connection.



108



109

TURBO REMOVAL

Remove the two oil drain/mounting pedestal bolts from the rear of the intake manifold.

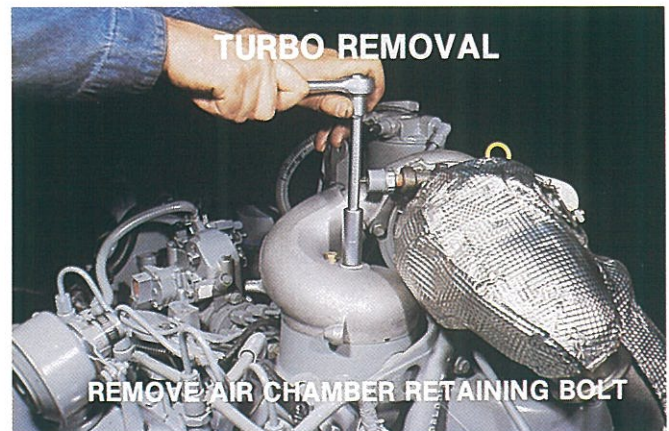

110

TURBO REMOVAL

Remove the air chamber hold down bolt.

SERVICE TIPS

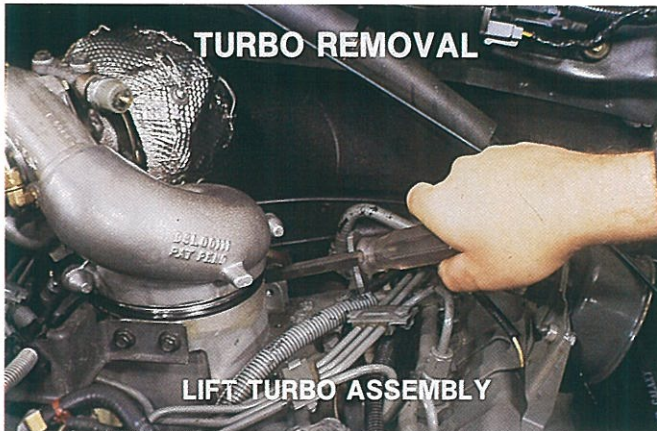

111

TURBO REMOVAL

Remove air chamber from the turbocharger compressor outlet.



112



113

TURBO REMOVAL

Position the turbocharger towards the heater housing and remove the two nuts securing the center housing to the drain pedestal.

SERVICE TIPS

TURBO REMOVAL

Slide the drain pedestal off the center housing and lift turbocharger assembly out of engine compartment.



114



115

TURBO INSPECTION

Remove wastegate housing and check turbocharger endplay by moving shaft back and forth. .001" - .004" is allowable.

TURBO INSPECTION

Check turbocharger radial shaft movement by lifting the shaft up and rotating the shaft to check for any compressor or turbine wheel to housing contact. If any wheel contact is noticed, the turbocharger must be replaced or repaired.



116

SERVICE TIPS



117

CENTER SECTION REPLACEMENT

A center section will be available for service parts to expedite field repairs in conjunction with re-man turbos and individual component parts.

CENTER SECTION REPLACEMENT

Scribe line on compressor housing and center section to reference during assembly.

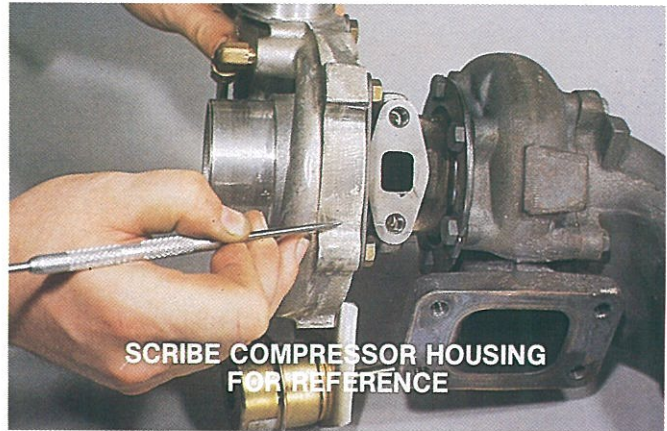

118

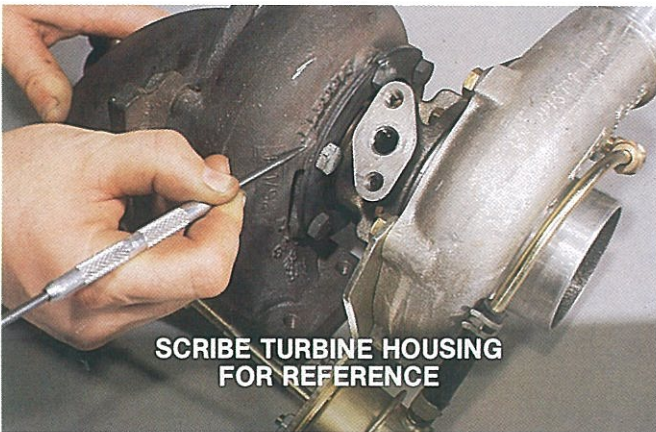

119

CENTER SECTION REPLACEMENT

Also scribe reference marks on the turbine housing in order to ease re-assembly.

SERVICE TIPS

CENTER SECTION REPLACEMENT

Remove compressor housing bolts and clamps.

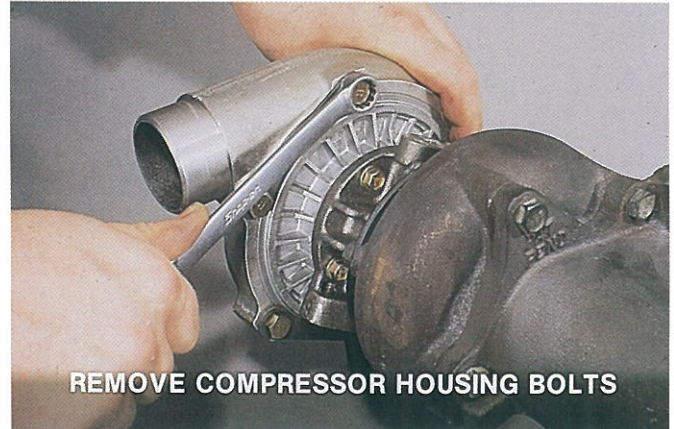

REMOVE COMPRESSOR HOUSING BOLTS

120



REMOVE COMPRESSOR HOUSING

121

CENTER SECTION REPLACEMENT

Separate compressor housing from turbocharger. Inspect for wheel rub.



REMOVE TURBO HOUSING BOLTS AND CLAMPS

122

CENTER SECTION REPLACEMENT

Remove turbine housing bolts and clamps.

SERVICE TIPS



123

CENTER SECTION REPLACEMENT

Separate turbine housing from center section of turbocharger. Inspect for wheel rub.

CENTER SECTION REPLACEMENT

Visually inspect compressor and turbine wheels for damage.

If wheel damage is observed, turbocharger will have to be repaired or replaced.



124

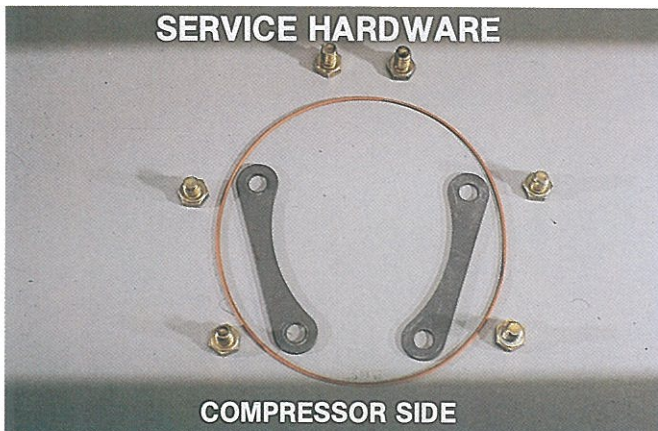

125

CENTER SECTION REPLACEMENT

Hardware to attach compressor housing to center section includes bolts, clamps, and an "O" ring.

SERVICE TIPS

CENTER SECTION REPLACEMENT

Hardware used to secure the turbine housing to the center section includes bolts and clamps.

Anti-Seize compound should be used when bolts are installed.

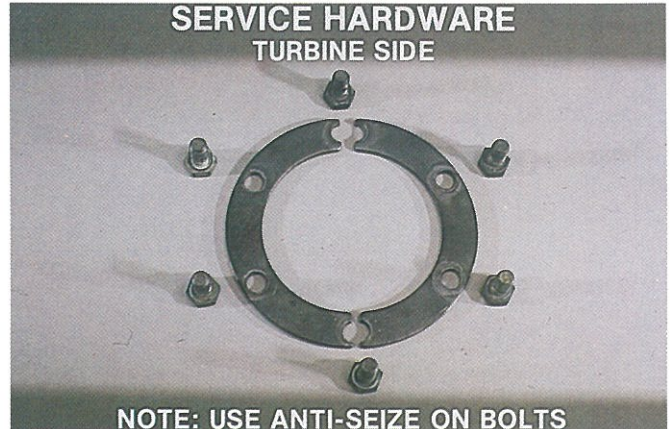

126



127

CENTER SECTION REPLACEMENT

Carefully install the center section into the turbine housings.

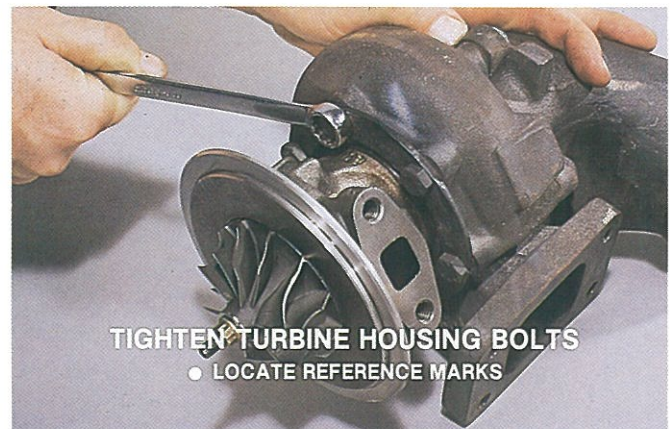

128

CENTER SECTION REPLACEMENT

After properly aligning turbine housing and center section, apply anti-seize compound to bolts, install and tighten.

SERVICE TIPS



129

CENTER SECTION REPLACEMENT

Verify the position of the "O" ring and install compressor housing to center section.

CENTER SECTION REPLACEMENT

Align reference marks, then tighten compressor bolts.

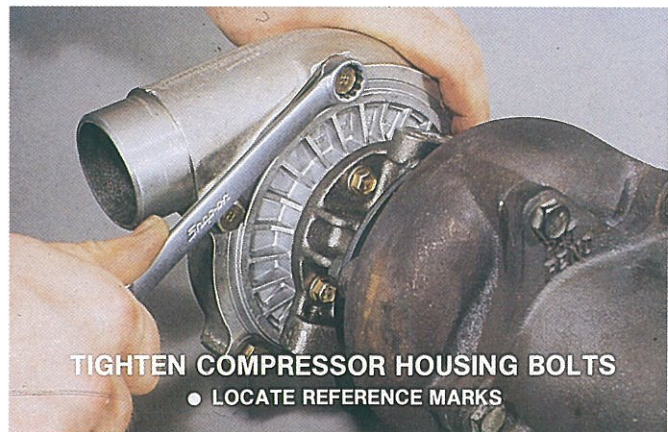

130

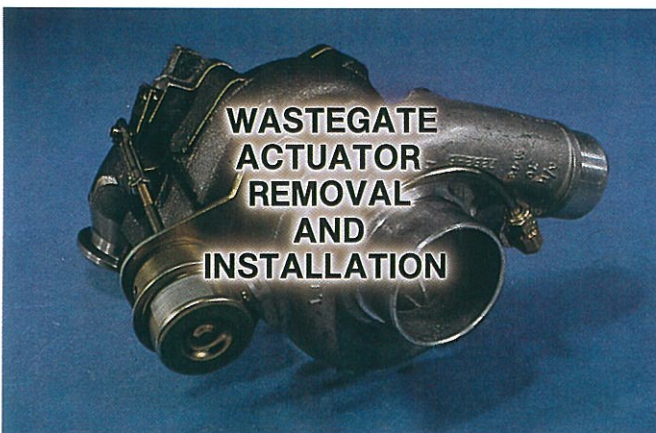

131

WASTEGATE ACTUATOR REMOVAL AND INSTALLATION

SERVICE TIPS

ACTUATOR REMOVAL

Remove clip which secures actuator rod to wastegate.

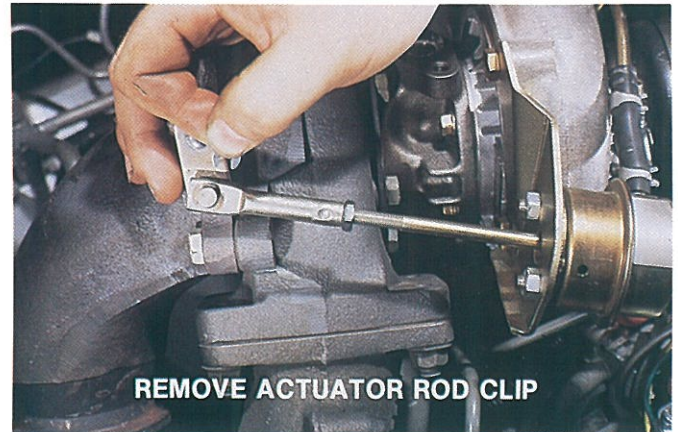

REMOVE ACTUATOR ROD CLIP

132



REMOVE ACTUATOR BRACKET
RETAINING BOLTS

133

ACTUATOR REMOVAL

Remove actuator bracket retaining bolts.



REMOVE BOOST SIGNAL HOSE
FROM ACTUATOR

134

ACTUATOR REMOVAL

Remove boost signal hose from actuator canister.

SERVICE TIPS

SERVICE PART

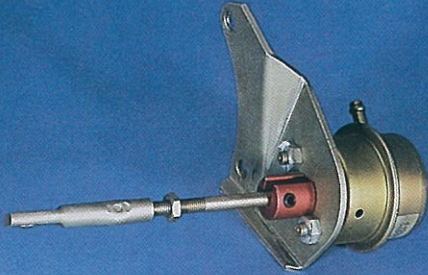

135

ACTUATOR INSTALLATION

The new service part actuator is supplied with a locking collar on the control rod. The locking collar provides two functions:

- Provides the correct pre-load on the spring
- Protects the diaphragm during shipping and storage

ACTUATOR INSTALLATION

To install actuator, start by attaching boost signal hose to actuator canister.

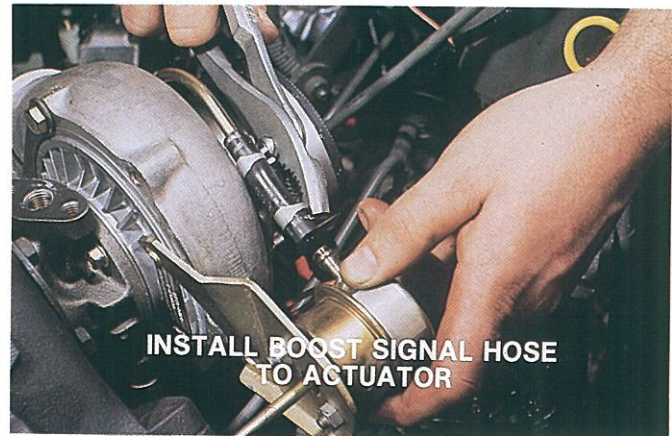

136

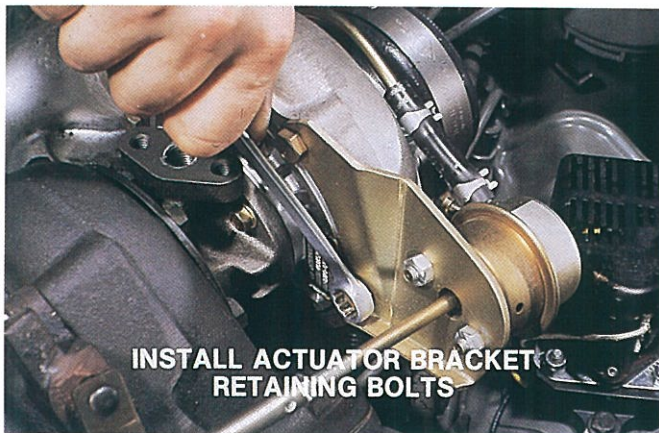

137

ACTUATOR INSTALLATION

Install bolts securing actuator bracket to compressor housing.

SERVICE TIPS

ACTUATOR INSTALLATION

On service replacement actuators with wastegate fully closed, adjust rod end to wastegate lever and install clip. Lock rod end in place.

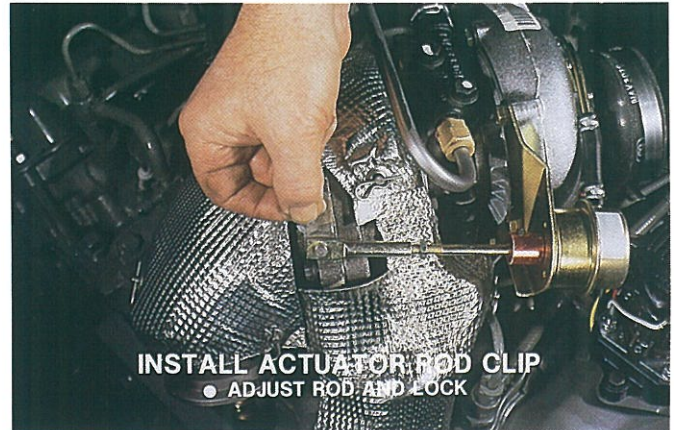

138

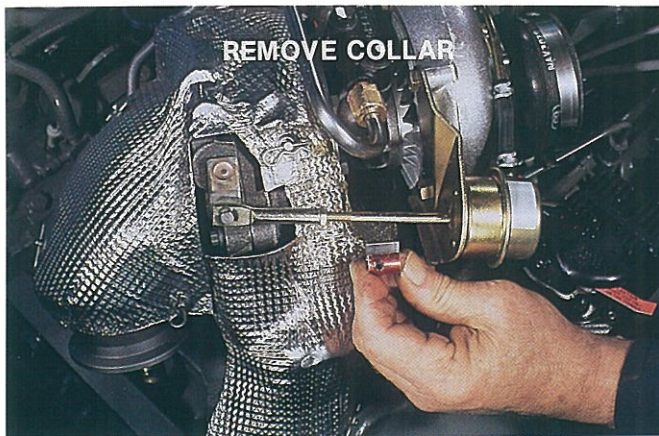

139

ACTUATOR INSTALLATION

Remove lock collar from actuator rod when a service part replacement is being installed.

TURBO INSTALLATION

To ease turbocharger installation, all mounting and exhaust joints will be loosely assembled until turbo is completely in place. Then all joints should be tightened.

Following is the procedure:

Position the oil drain mounting pedestal in vee of engine. Verify "O" ring seals are in place.

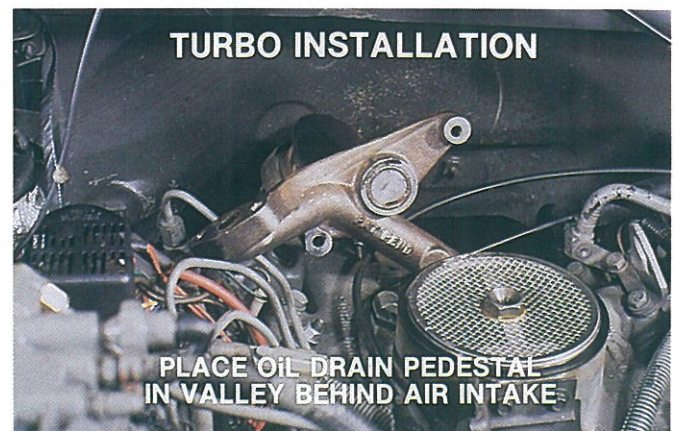

140

SERVICE TIPS

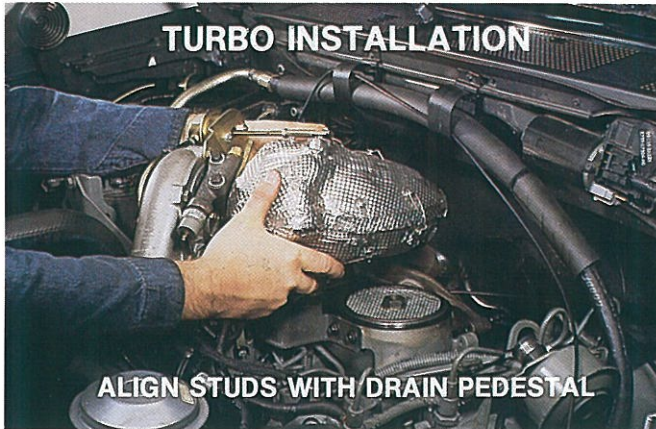

141

TURBO INSTALLATION

Position turbocharger in engine compartment, then slide pedestal up on studs in center housing of turbocharger.

TURBO INSTALLATION

Install and tighten nuts to secure turbocharger to drain pedestal.

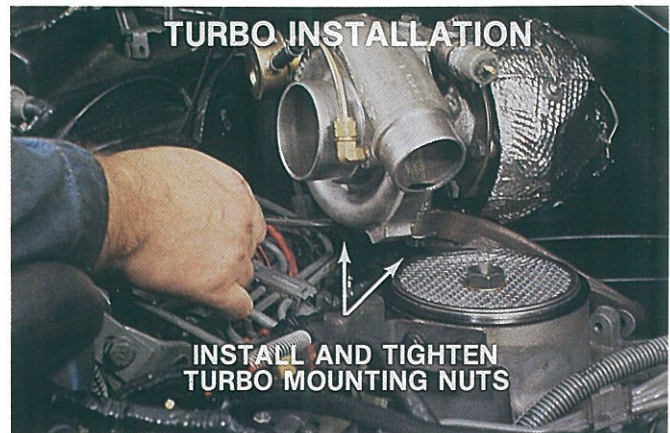

142

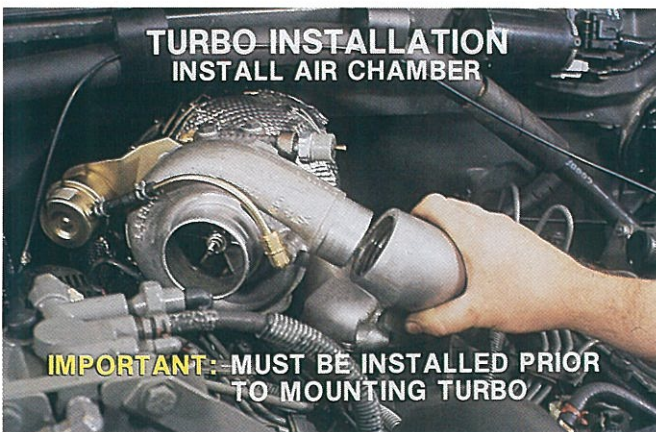

143

TURBO INSTALLATION

- Install air chamber on turbocharger
- Position Marmon clamp on exhaust outlet flange
- Verify large square cut "O" ring is on intake manifold

SERVICE TIPS

TURBO INSTALLATION

Position pedestal drain into grommet in valley pan and loosely install the two mounting bolts at the rear of intake manifold.

Note: verify accelerator/cruise cables are routed correctly and move freely.

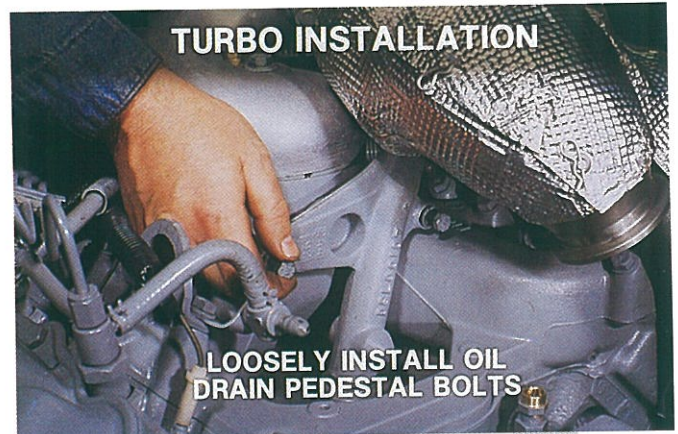

144

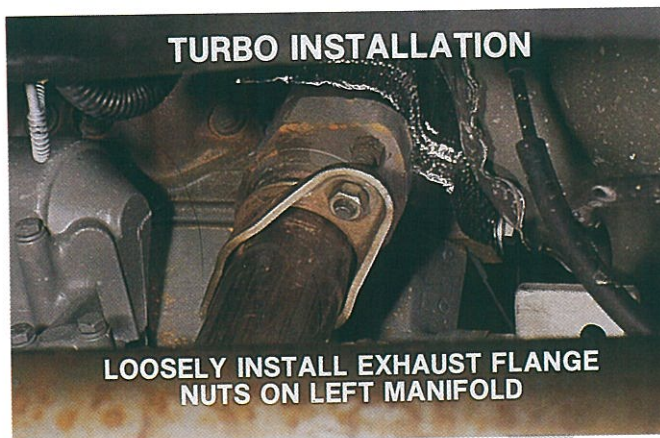

145

TURBO INSTALLATION

From under vehicle, position crossover pipe on left exhaust manifold and loosely install the two flange mounting nuts.

TURBO INSTALLATION

Using a long drift punch, tap "Y" collector into turbine inlet casting.



146

SERVICE TIPS

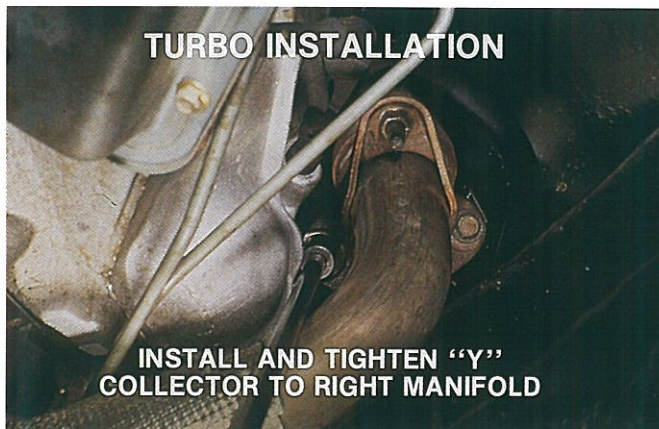

147

TURBO INSTALLATION

Install and tighten two bolts to secure "Y" collector to right exhaust manifold.

TURBO INSTALLATION

Tighten two left exhaust manifold to crossover pipe flange mounting nuts.

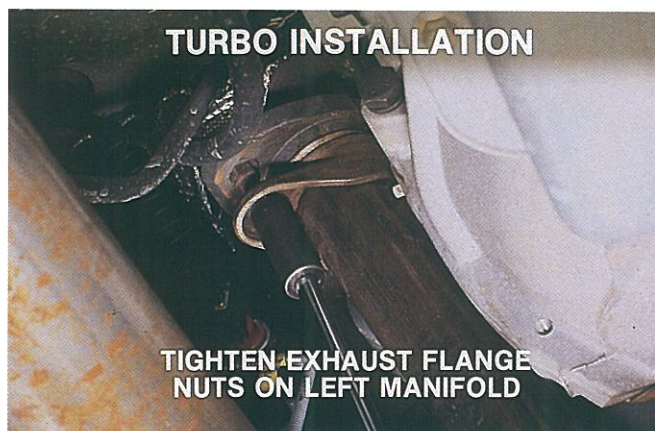

148



149

TURBO INSTALLATION

Tighten the two oil drain/mounting pedestal bolts at rear of intake manifold.

SERVICE TIPS

TURBO INSTALLATION

Position Marmon clamp on exhaust outlet casting and down pipe, then tighten clamp.

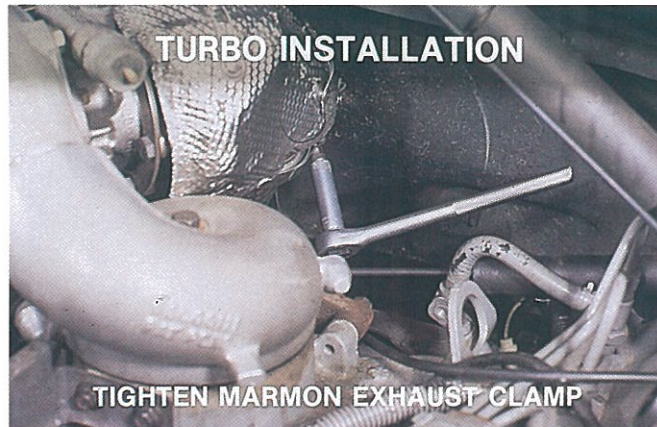

150

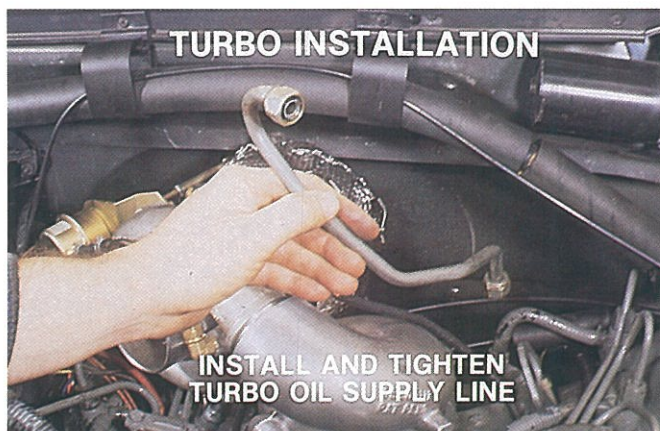

151

TURBO INSTALLATION

Install turbocharger oil supply line and tighten nuts.



152

TURBO INSTALLATION

Install oil pressure sender wire.

SERVICE TIPS



153

TURBO INSTALLATION

- Verify copper seal is on hold down bolt
- Install hold down bolt and torque to 10 lbs. ft. min.—20 lbs. ft. max.

CAUTION: DO NOT OVERTIGHTEN.

FUEL INJECTION PUMP REMOVAL AND INSTALLATION

Fuel injection pump removal and installation procedures on the 7.3L IDI Turbocharged Diesel Engine change slightly when compared to current published procedures.

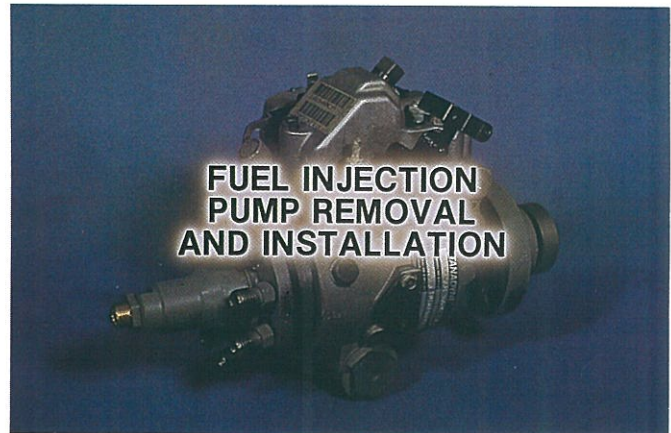

154

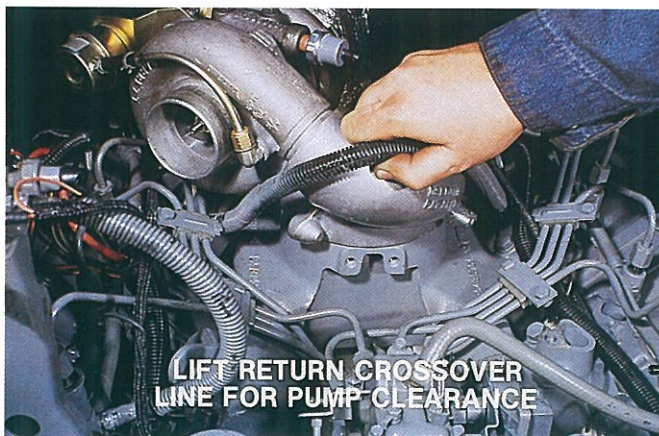

155

INJECTION PUMP REMOVAL

Follow standard procedure for pump removal and prior to sliding the pump rearward off the three mounting studs, pull fuel return crossover line up out of the vee of the engine.

SERVICE TIPS

INJECTION PUMP REMOVAL

- Move pump rearward to obtain access to the top stud
- Remove stud from gear housing as shown

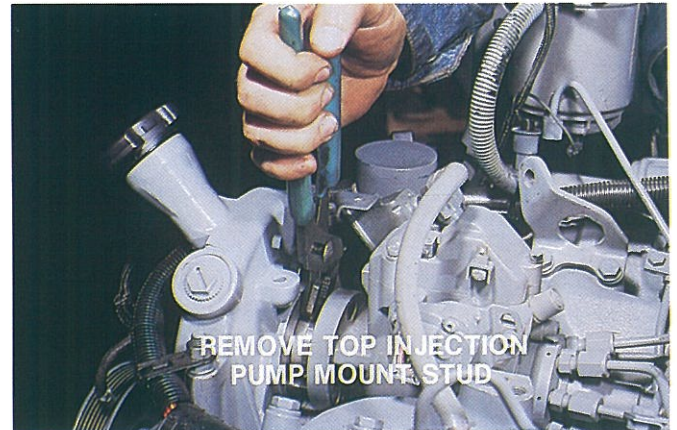

156

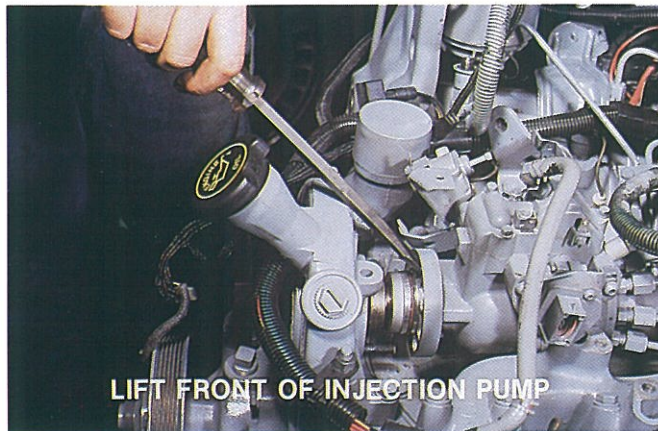

157

INJECTION PUMP REMOVAL

- With a screwdriver or equivalent, pry rearward slightly and lift upward as shown
- Pull injection pump with lines attached out of the engine compartment

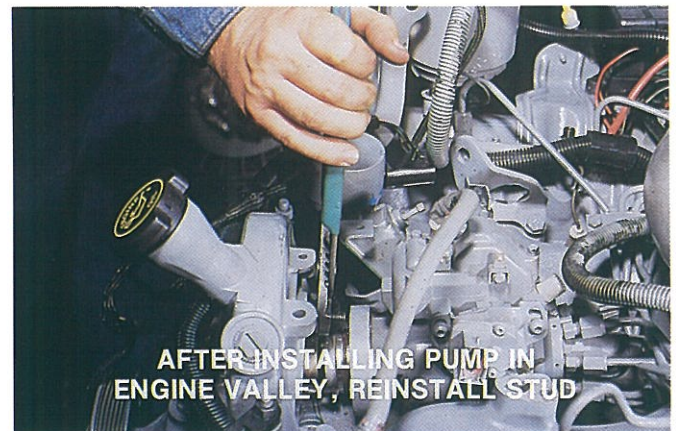

158

INJECTION PUMP INSTALLATION

- After the pump has been positioned on the engine, re-install the top stud
- Reposition fuel return crossover line down in the vee
- Complete installation in accordance to published procedures

SERVICE TIPS

FASTENER TORQUE ANGLE

159

TORQUE ANGLE

An additional turn of a fastener to a specified angle past its final torque.

TORQUE ANGLE

- Torque main bearing cap bolts by the published two step procedure
- First Step — 75 lbs. ft.
- Second Step — 95 lbs. ft.

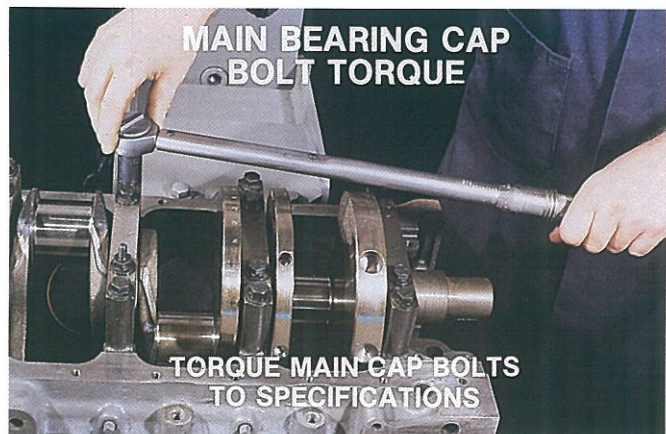

160

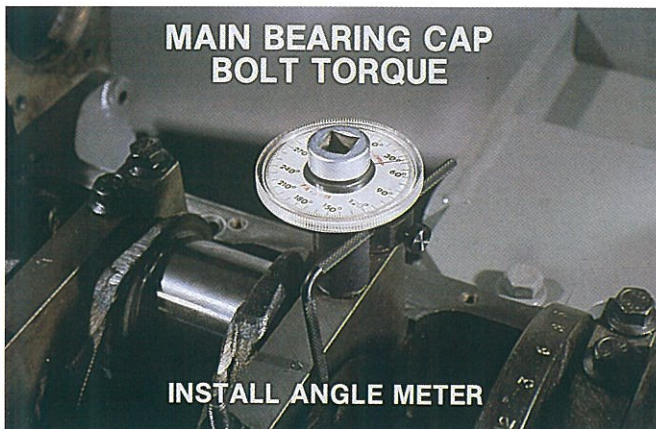

161A

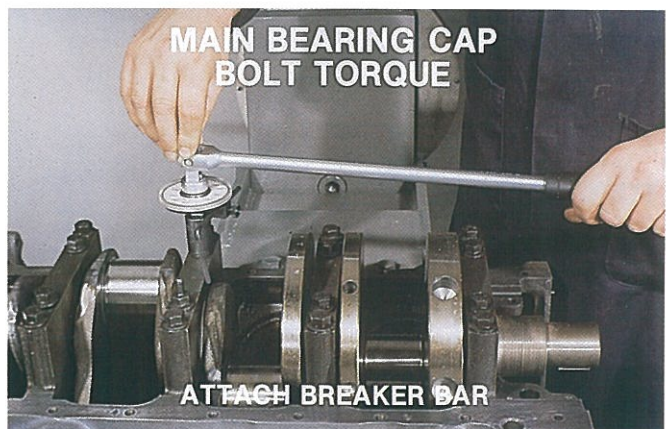

161B

TORQUE ANGLE

Install angle meter and breaker bar to 5/8" socket.

SERVICE TIPS

TORQUE ANGLE

Tighten main bearing cap bolt an additional 45°

An additional 1/8 of a turn is equal to 45°

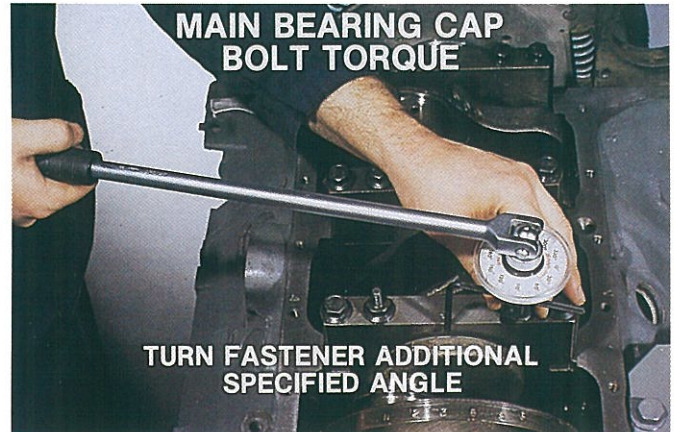

162

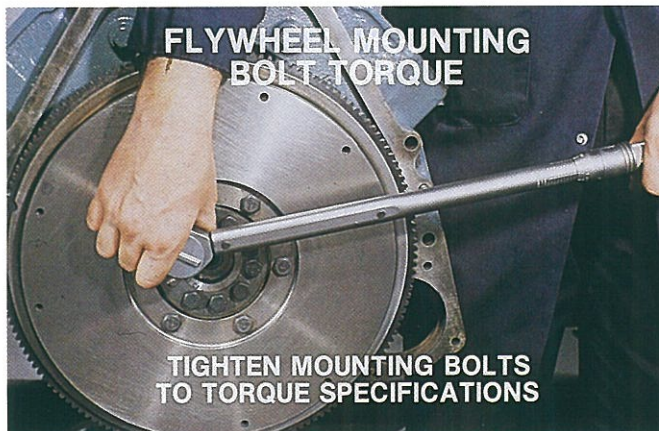

163

TORQUE ANGLE

Torque angle is also used on flywheel mounting bolts. Start by tightening bolts with a torque wrench to specified torque, 47 lbs. ft.

TORQUE ANGLE

Install angle meter and breaker bar on 5/8" socket.

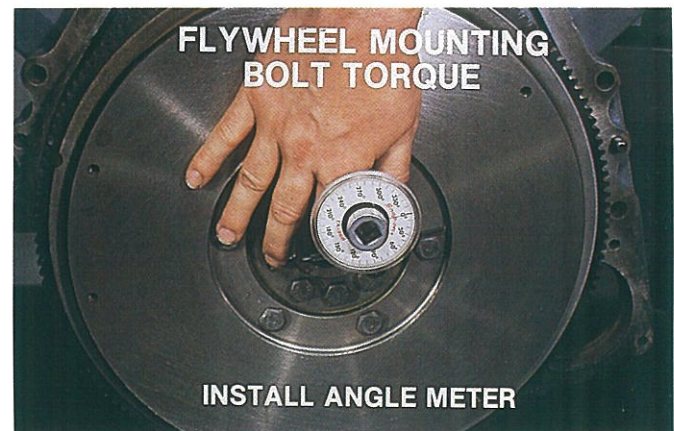

164

SERVICE TIPS

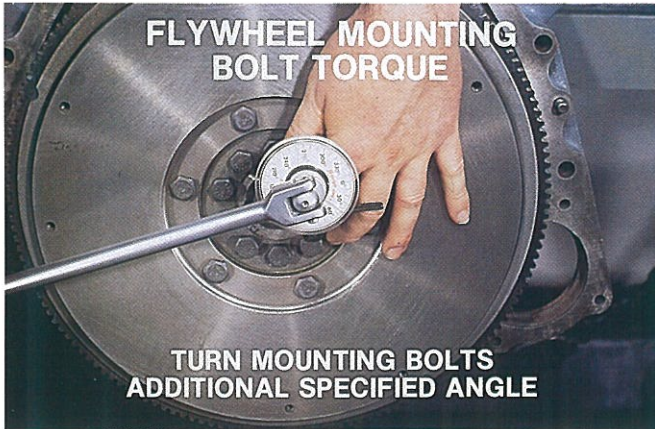

165

TORQUE ANGLE

Tighten flywheel bolts an additional 45°

An additional 1/8 of a turn is equal to 45°

TEST AIR INDUCTION

Pressure testing the air induction system verifies the integrity of the air intake system and locates any leakage that might be in the system.

AIR INDUCTION TEST

- VERIFIES INTEGRITY OF THE SYSTEM
- LOCATES LEAKAGE IN THE SYSTEM

166



167

TEST AIR INDUCTION

To pressure test the air induction system, modification to an air cleaner element will be required.

- With duct tape or equivalent, cover the clean air side of the element

SERVICE TIPS

TEST AIR INDUCTION

The CDR hose has to be removed from the upper air cleaner housing. The spud opening has to be capped and clamped.



PLUG FOR CDR HOSE OPENING

168

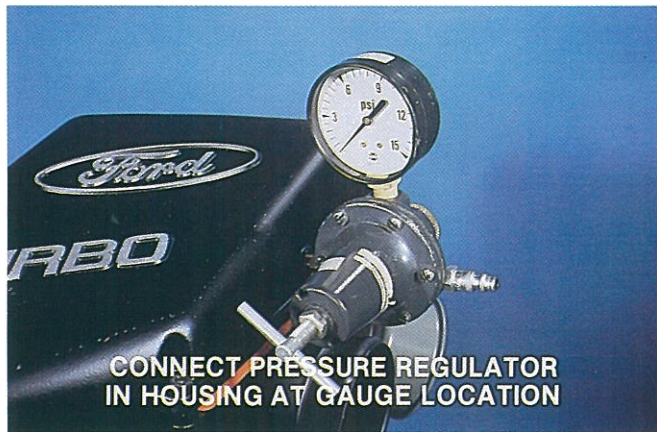

CONNECT PRESSURE REGULATOR
IN HOUSING AT GAUGE LOCATION

169

TEST AIR INDUCTION

- Install modified air cleaner element
- Remove restriction gauge
- Install pressure regulator in upper housing

TEST AIR INDUCTION

With shop air connected to regulator valve, adjust to maintain 5-8 psi in the air induction system.

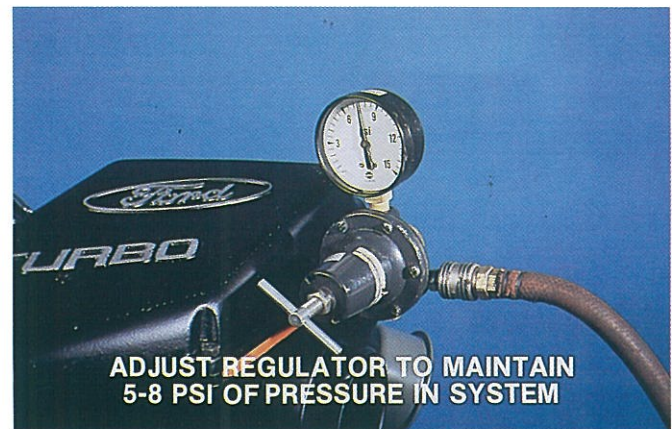

ADJUST REGULATOR TO MAINTAIN
5-8 PSI OF PRESSURE IN SYSTEM

170

SERVICE TIPS

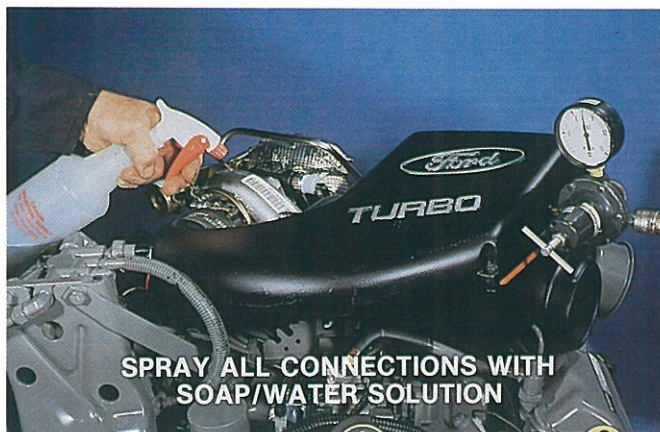

171

TEST AIR INDUCTION

Spray all air induction system joints and connections with a soap/water solution.

NOTE: Mr. Bubble works very well.

- Inspect for blowing bubbles
- Bubbles indicate air leakage
- Slight leakage at compressor back plate is acceptable

CHASSIS CHANGES

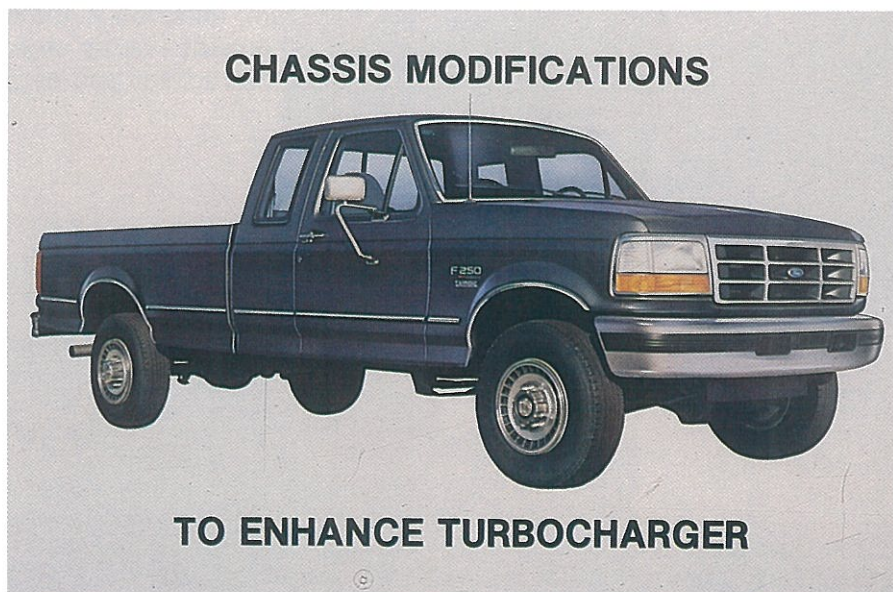

172

CHASSIS CHANGES

Several changes to the F-series pick up truck have been made to enhance the turbocharger package. These include:

- Slotted front bumper
- Air dam below radiator
- Re-configured dipstick for E40D
- Engine cooling fan clutch
- Micro processor for E40D
- Low restriction exhaust

CHASSIS CHANGES

BUMPER SLOTS

The three slots added to the front bumper provides increased air flow for engine cooling.

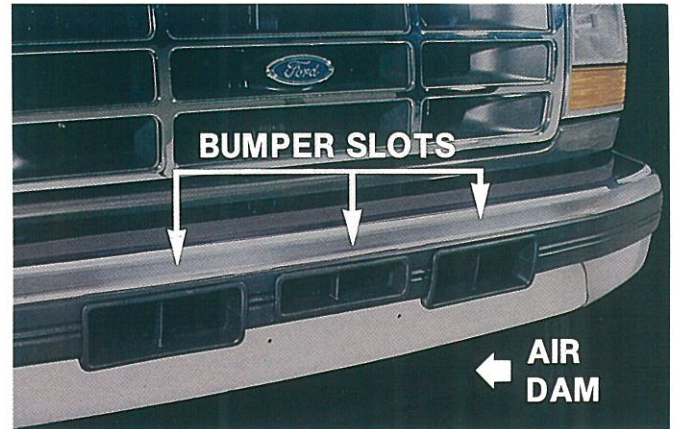

173

AIR DAM BETTER AIR MOVEMENT THROUGH

- RADIATOR
- ENGINE COMPARTMENT

AIR DAM

An air dam, attached to the radiator lower support, provides better air movement through the radiator and engine compartment.

174

E40D DIPSTICK

The E40D transmission dipstick and tube has been reconfigured to provide exhaust clearance. The new tube is supported at the engine by a stud used to secure the right valve cover.

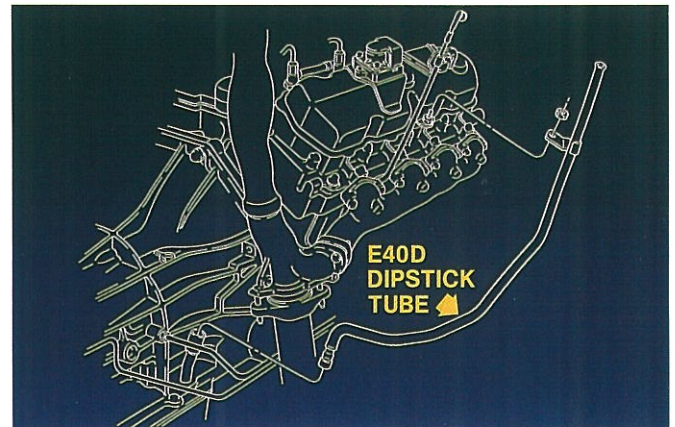

175

CHASSIS CHANGES

E40D TRANSMISSION

- MICROPROCESSOR RECALIBRATED
- MATCHES TURBOCHARGED 7.3L IDI
-UNIQUE TO THIS APPLICATION

176

E40D MICROPROCESSOR

The microprocessor controlling the E40D has been re-calibrated to provide durability in the turbocharger application.

EXHAUST SYSTEM

To enhance the engine's air flow capability, a low restriction exhaust system has been utilized.

- The system is designed to operate with a 2" Hg-3" Hg (4-6 psi) of back pressure

EXHAUST FLOW

- LOW RESTRICTION EXHAUST SYSTEM
- ENHANCES AIR FLOW CAPABILITY

177

COOLING FAN CLUTCH

- REDESIGNED TO INCREASE FAN SPEED
- ENHANCE ENGINE COOLING
- P/N-F3TA-8A616-GA

178

FAN CLUTCH

The engine's fan clutch has been redesigned to increase fan speed at all engine rpm to enhance engine cooling.

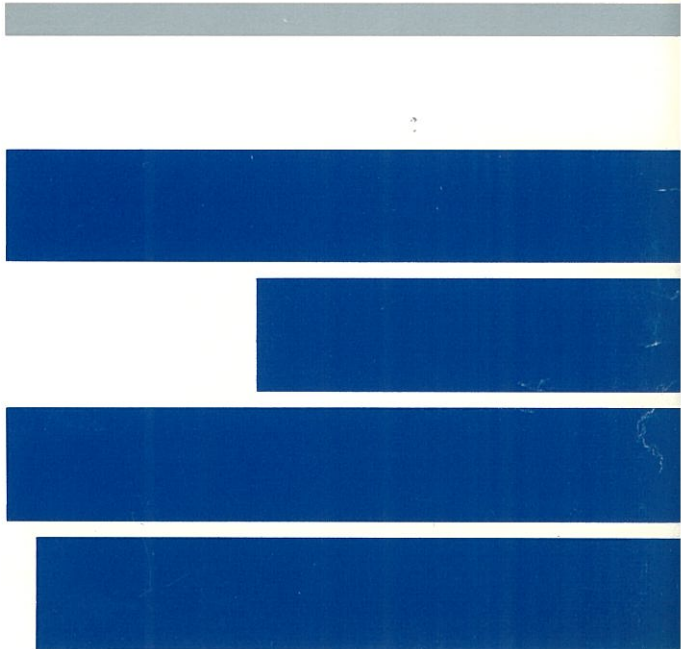
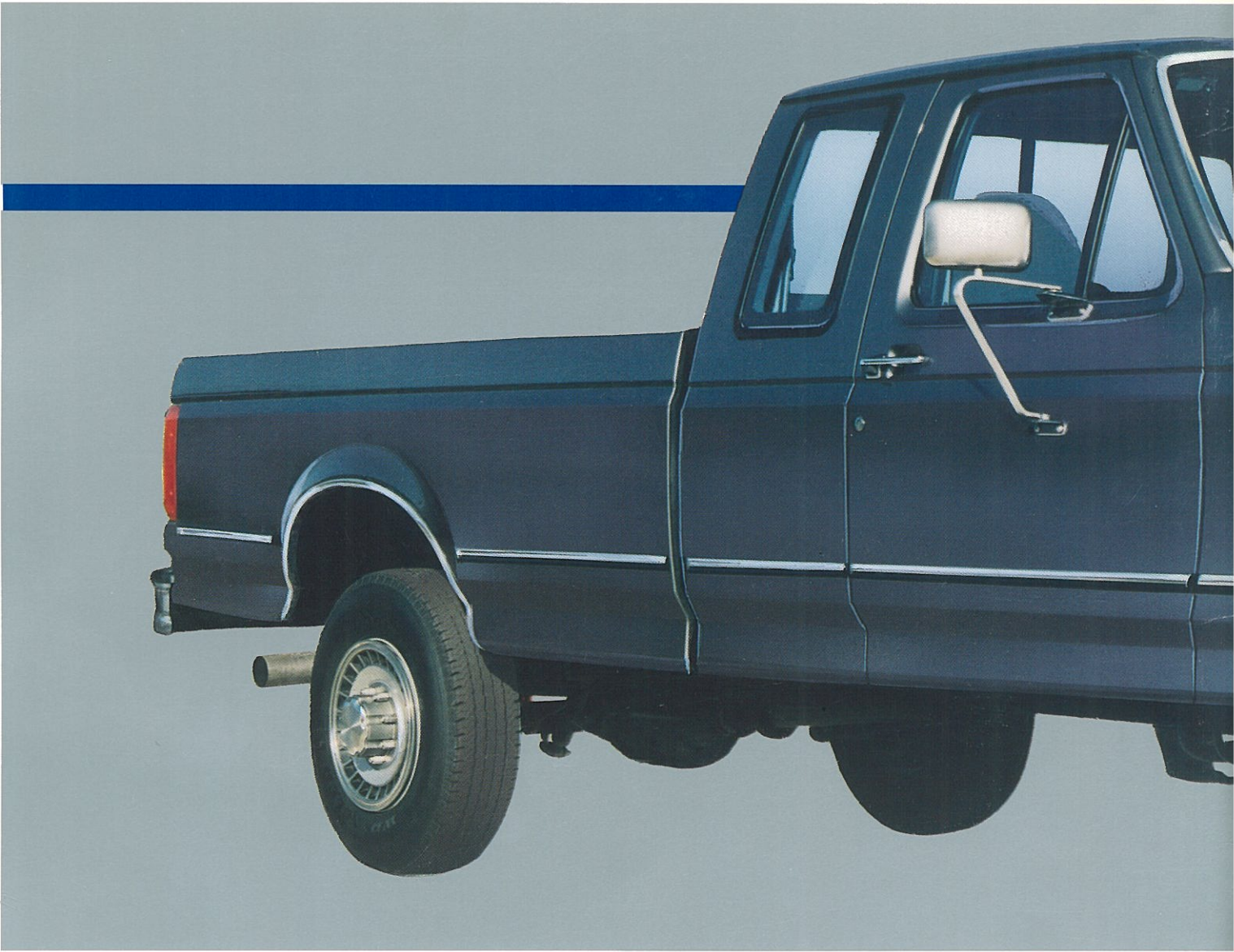



ENGINE PERFORMANCE CHART 7.3L (444CID) **TURBOCHARGED** DIESEL ENGINE DIAGNOSTIC GUIDE

—NOTE—
IF CONCERN IS FOUND, SERVICE AS REQUIRED. IF THIS CORRECTS THE CONDITION, IT IS NOT NECESSARY TO COMPLETE THE REMAINDER OF THE PERFORMANCE CHART.

CUSTOMER NAME		DEALER NAME & LOCATION		1863 CLAIM NO.	DATE
MODEL YEAR	VEHICLE SERIAL NO.	ENGINE SERIAL NO.	INJECTION PUMP SERIAL NO.		ODOMETER
CHASSIS STYLE	GVW	TRANSMISSION	AMBIENT TEMPERATURE	TYPE OF SERVICE PERSONAL <input type="checkbox"/> COMMERCIAL <input type="checkbox"/>	
TURBOCHARGER S/N			TURBOCHARGER P/N		

CUSTOMER CONCERN * (PLEASE LIST CONCERN(S) IN THIS BOX).

- If concern is exhaust smoke, see "Evaluating Normal Exhaust Smoke", right lower corner.
- If concern is hard start, refer to TSB No.: 90-26-11
- For vehicle performance evaluation, refer to TSB No.: 89-12-8

TESTS			
UNLESS OTHERWISE SPECIFIED ALL TESTS ARE TO BE RUN WITH TRANSMISSION IN NEUTRAL (PARK) AND REAR WHEELS OFF THE GROUND.			
1. EXTERNAL LEAKAGE — See Illustration — Reverse Side			
<input type="checkbox"/> Oil <input type="checkbox"/> Air Intake <input type="checkbox"/> Water <input type="checkbox"/> Fuel Record location of leaks in "Comments". Record location of leaks on Illustration — Reverse Side			
INSTRUMENT		1ST CHECK	2ND CHECK ▲
Visual Check <input type="checkbox"/>			
2. ACCELERATOR LINKAGE — See Illustration — Reverse Side			
Throttle lever contacts stop at full pedal depression.			
INSTRUMENT		1ST CHECK	2ND CHECK ▲
Visual Check <input type="checkbox"/>			
3. EXHAUST SYSTEM CONDITION			
Inspect for dents or kinks which could cause a restriction. Record defects in "Comments".			
INSTRUMENT		CHECK	
Visual Check <input type="checkbox"/>			
4. TURBOCHARGER BOOST — See Illustration — Reverse Side			
Remove air cleaner assembly and connect 0-15 psi pressure gauge to the boost test port on the air chamber. Re-install the air cleaner.			
<ul style="list-style-type: none"> • With automatic transmission, perform a torque converter stall test (1680-2100) rpm. Observe P.S.I. reading. • With manual transmission in 2nd gear, accelerate from 1200 to 2800 rpm. Observe P.S.I. reading. 			
INSTRUMENT		GUIDELINE DATA	1ST CHECK 2ND CHECK
0-15 psi Gauge		5 PSI BOOST MINIMUM	
NOTE: IF BOOST IS WITHIN LIMITS PERFORMANCE IS ACCEPTABLE. STOP			
• If boost is low, go to test 5.			
5. WASTEGATE ACTUATOR CONDITION — See Illustration — Reverse Side			
Connect 0-30 psi gauge and hand pump to actuator. Apply pressure to actuator with hand pump. Actuator rod should begin to move at 12-15 psi. Full actuator rod travel should occur at 20-22 psi. Observe pressure gauge for 30 seconds after 20-22 psi has been attained. No decrease in pressure should occur.			
INSTRUMENT		GUIDELINE DATA	1ST CHECK 2ND CHECK
0-30 PSI GAUGE		A. ROD TRAVEL START AT 12-15 PSI B. FULL ROD TRAVEL AT 20-22 PSI C. NO DECAY OF APPLIED PRESSURE	
<ul style="list-style-type: none"> • If actuator rod fails to move, remove rod from wastegate and check wastegate for freedom of movement. • If wastegate is free, replace actuator. • If wastegate will not move, free up wastegate or replace housing containing wastegate. 			
6. CHECK FOR FUEL QUALITY — See Illustration — Reverse Side			
A. CHECK FOR AIR IN FUEL			
Install an appropriate length of clear PVC hose in place of the rubber hose on the fuel filter continuous vent. Run engine at 3000 RPM for 2 minutes and observe clear fuel hose for bubbles in fuel with engine at 3000 RPM. Fuel should be free of bubbles within 2 minutes. Correct fuel flow direction is from the fuel filter towards the fuel return system (injection nozzles). Fuel flow in the opposite direction indicates an inoperative check ball in the vent fitting and a restricted fuel supply system.			

TESTS			
INSTRUMENT GUIDELINE DATA CHECK			
Clear PVC Hose NO BUBBLES Front Tank Rear Tank			
<ul style="list-style-type: none"> • Flow direction OK and bubbles not present — go to test 6B. • Flow direction OK and bubbles present — go to Fuel System Diagnostic Procedure (see Car/Truck Emission Diagnosis Shop Manual, Volume H, and return to test 6A when leak is determined). • Flow direction NOT OK — Replace continuous vent assembly. Go to test 6B. 			
B. CHECK FOR FUEL CONTAMINATION			
Obtain a fuel sample and visually examine the sample of fuel in a clear container (including bottom of container) for particles, clouding or other liquid contamination such as water. Sample must be taken at the Fuel Priming Vent (Schrader valve) on the filter header.			
INSTRUMENT		CHECK	
Clear Container			
<ul style="list-style-type: none"> • If no contamination is found — go to test 7. • If contamination is found — replace filter and clean or repair chassis fuel system. Go to test 7. 			
7. FUEL SUPPLY SYSTEM — See Illustration — Reverse Side			
A. CHECK FUEL FILTER OUTLET PRESSURE — Record "Value" Below			
Measure at 3000 RPM with accessories turned off.			
INSTRUMENT		GUIDELINE DATA	1ST CHECK 2ND CHECK ▲
0-15 PSI Gauge and 5651 Adapter		1.0 PSI MINIMUM	Front Tank Rear Tank Front Tank Rear Tank
<ul style="list-style-type: none"> • If pressure meets guideline, go to test 7C. • If pressure is low, go to test 7B. 			
B. FUEL SUPPLY PUMP OUTLET PRESSURE — Record "Value" Below			
Remove Fuel Priming Vent (Schrader valve) and install gauge. Measure at 675 RPM with accessories turned off.			
INSTRUMENT		GUIDELINE DATA	1ST CHECK 2ND CHECK ▲
0-15 PSI Gauge and 3019 Adapter		2.0 PSI MINIMUM	Front Tank Rear Tank Front Tank Rear Tank
<ul style="list-style-type: none"> • If pressure meets guideline, replace fuel filter and repeat test 7A. • If pressure is low, go to test 7C. 			
② Leave adapter 5651 from test 7A installed but capped.			
C. FUEL PUMP CAPACITY ** — Record Volume in 30 sec.			
Measure at 675 RPM with accessories turned off.			
INSTRUMENT		GUIDELINE DATA	1ST CHECK 2ND CHECK ▲
Graduated 1 Qt. Container and 3019 Adapter		MINIMUM OF 1 PINT IN 30 SECONDS	Front Tank Rear Tank Front Tank Rear Tank
<ul style="list-style-type: none"> • Pressure and volume meet guideline — go to test 8. • Pressure OK and volume NOT OK — go to test 7D. • Volume OK and pressure NOT OK — replace fuel supply pump and repeat test 7A. • Pressure and volume NOT OK — go to test 7D. 			
D. CHECK RESTRICTION AT SUPPLY PUMP INLET — Record "Value" Below			
Measure at 3000 RPM with accessories turned off.			
INSTRUMENT		GUIDELINE DATA	1ST CHECK 2ND CHECK ▲
0-30 In.-Hg. Vacuum Gauge and 5632 Adapter		LESS THAN 6 IN.-HG. VACUUM	Front Tank Rear Tank Front Tank Rear Tank
<ul style="list-style-type: none"> • If vacuum is 6 In.-Hg. or greater — repair restriction in chassis fuel system and repeat test 7A. • If vacuum is less than 6 In.-Hg. — replace fuel supply pump and repeat test 7A. 			

TESTS			
8. CHECK FUEL RETURN LINE PRESSURE — See Illustration — Reverse Side			
Check pressure at junction of engine adapter and chassis return hose. NOTE: Return line removed in test 6A must be reconnected.			
Measure at 3000 RPM with accessories turned off. Record "Value" Below.			
INSTRUMENT		GUIDELINE DATA	1ST CHECK 2ND CHECK ▲
0-15 PSI Gauge and 5663 Adapter		LESS THAN 2.0 PSI	Front Tank Rear Tank Front Tank Rear Tank
9. AIR INTAKE RESTRICTION — See Illustration — Reverse Side			
Measure at 3000 RPM with accessories turned off. Record "Value" Below.			
Reset air filter restriction gauge (Filter Minder). Operate engine at 3000 rpm. If no restriction is measured, remove filter minder and install 014-00761 test kit magnahelic gauge and retest restriction.			
INSTRUMENT		GUIDELINE DATA	1ST CHECK 2ND CHECK
Filter Minder or 014-00761 Test Kit		BETWEEN 2" AND 30" H ₂ O	
<ul style="list-style-type: none"> • If filter minder indicates replacement necessary, replace and retest. • If above 30", replace filter element and retest. • If less than 2" inspect for leaks in filter system. • If within guidelines, go to test 10. 			
10. LOW IDLE (RPM) — See Illustration — Reverse Side			
A. Manual transmission in neutral position.** Record "Value" Below.			
B. Automatic transmission in drive position.**			
INSTRUMENT		GUIDELINE DATA	1ST CHECK 2ND CHECK ▲
078-00200 Dynamic Timing Meter and 078-00201 Adapter		SEE EMISSIONS LABEL	
11. INJECTION PUMP TIMING — See Illustration — Reverse Side			
Attach the clamp to the line pressure sensor on the No. 1 injection nozzle for F-Series, and connect the dynamic timing meter. Dial -20° offset on the meter. Disconnect cold start advance solenoid connector from the solenoid terminal. Maintain 2000 RPM with engine at operating temperature and record dynamic timing in Box A. Apply battery voltage to solenoid terminal, maintain 2000 RPM and record dynamic timing in Box B. (Record "Values" Below).			
INSTRUMENT		GUIDELINE DATA	1ST CHECK 2ND CHECK
078-00200 Dynamic Timing Meter and 078-00201 Adapter		A. 8° ±2° BTDC @ 2000 RPM. B. CHECK WITH POWER TO ADVANCE SOLENOID	
<ul style="list-style-type: none"> • Advance Timing Check (B) should be 1° (min.) more advanced than Timing Check (A). • If B is less than 1.0° advance from A, replace fuel injection pump. 			
12. CHECK INJECTION PUMP TRANSFER PRESSURE — See Illustration — Reverse Side			
NOTE: PERFORM ONLY IF 1ST TIMING CHECK (STEP 11) WAS NOT WITHIN SPECIFICATION.			
SAFETY PRECAUTION			
THE COMPRESSOR INLET SAFETY GUARD MUST BE INSTALLED WHEN ENGINE IS RUNNING WITHOUT AIR CLEANER ATTACHED.			
Measure at 3000 RPM with accessories turned off. Record "Value" Below.			
INSTRUMENT		GUIDELINE DATA	1ST CHECK 2ND CHECK ▲
T83T-9000-A 0-160 PSI Gauge 5650 Adapter		90-120 PSI @ 3000 RPM	
<ul style="list-style-type: none"> • If pressure is not to specification, replace fuel injection pump. NOTE: WARRANTY CLAIMS FOR THE INJECTION PUMP WILL NOT BE ACCEPTED UNLESS ALL TAMPER RESISTANT SEALS ARE INTACT AND THE COMPLETED ENGINE PERFORMANCE CHART (VALUES RECORDED) IS SUBMITTED WITH THE RETURNED PART. 			

TESTS			
13. CHECK INJECTION LINES AND INJECTION NOZZLES — See Illustration — Reverse Side			
NOTE: PERFORM ONLY IF ENGINE IS MISSING OR RUNNING ROUGHLY.			
Check injection lines for kinks and/or restrictions. Remove nozzles and test opening pressure and tip leakage on each nozzle. No other evaluation should be performed.			
CAUTION: Keep hands and other parts of the body away from the spraying nozzle. The liquid discharge leaves the nozzle tip with sufficient force to penetrate the skin and cause serious injury. The nozzle tip should be surrounded by a transparent receptacle if available.			
Opening Pressure and Tip Leakage			
A. Connect nozzle to nozzle tester. Bleed air from nozzle by pumping tester 10 times to insure steady fuel discharge from tip. Pump tester slowly and record highest pressure reached prior to the nozzle opening (discharging fluid) and record in Box A below.			
B. Ensure that nozzle body and tip are completely dry before starting test. Operate test to maintain pressure for 5 seconds at 200 PSI below nozzle pressure recorded in A for each nozzle. Nozzle tip can be wet in 5 seconds but a droplet should not fall.			
INSTRUMENT		GUIDELINE DATA	
014-00300 Injection Nozzle Tester		ENGINE CALIBRATION 389TR00 CODE ON NOZZLE BODY G MINIMUM OPENING PRESSURE 1450 PSI	RECORD "VALUES" BELOW
NOZZLE # 1 2 3 4 5 6 7 8			
A. Opening Pressure (PSI)			
B. Tip Leakage (OK/Not OK)			
<ul style="list-style-type: none"> • If nozzle is not to specification, replace nozzle assembly. NOTE: WARRANTY CLAIMS FOR REPLACEMENT OF THE NOZZLE(S) WILL NOT BE ACCEPTED UNLESS THE COMPLETED ENGINE PERFORMANCE CHART (VALUES RECORDED) IS SUBMITTED WITH THE RETURNED PART(S). 			
14. CRANKCASE PRESSURE — See Illustration — Reverse Side			
Measure pressure at oil fill pipe. Loosen crankcase depression regulator (CDR) valve. Insert clean cardboard between CDR valve and seal ring. Retighten CDR and insure dipstick is seated in tube. Remove cardboard upon completion of test.			
Measure at 3000 RPM with accessories turned off. Record "Value" Below.			
INSTRUMENT		GUIDELINE DATA	1ST CHECK 2ND CHECK ▲
014-00761 Test Kit plus 014-00743 & 5631 Adapters		MAXIMUM PRESSURE OF 6 IN. OF WATER	
<ul style="list-style-type: none"> • If pressure is not to specification, there is an internal engine concern. • IF THE PERFORMANCE CONCERN STILL EXISTS AFTER COMPLETION OF THE ENGINE PERFORMANCE CHART REPLACE THE INJECTION PUMP. NOTE: WARRANTY CLAIMS FOR THE INJECTION PUMP WILL NOT BE ACCEPTED UNLESS ALL TAMPER RESISTANT SEALS ARE INTACT AND THE COMPLETED ENGINE PERFORMANCE CHART (VALUES RECORDED) IS SUBMITTED WITH THE RETURNED PART. 			
EVALUATING NORMAL EXHAUST SMOKE			
BLUE-WHITE SMOKE CAN BE OBSERVED		BLACK SMOKE CAN BE OBSERVED	
<ul style="list-style-type: none"> • after engine startup at all ambient temperatures. • at low idle speeds after cold engine startup — this smoke will clear up soon after the vehicle is driven. 		<ul style="list-style-type: none"> • when pulling hard, such as going up a steep grade. • when heavily loaded, such as pulling a trailer or operating with a heavy load in the truck bed. • during heavy acceleration. 	
<ul style="list-style-type: none"> • when ambient temperature is below 50°F, blue-white smoke can return after the engine warm-up period due to extended idling time (ten minutes or more). 			
COMMENTS:			
THIS GUIDE SHOULD BE USED IN CONJUNCTION WITH THE CAR/TRUCK SHOP MANUAL - "ENGINE/EMISSIONS DIAGNOSIS" - VOLUME H.			
SERVICE TECHNICIAN		DATE	
DEALER SERVICE MANAGER		DATE	

*SEE REVERSE SIDE FOR TEST HARDWARE INSTALLATION

**ENGINE MUST BE AT NORMAL OPERATING TEMPERATURE

▲ 2ND CHECK SHOULD BE PERFORMED ONLY AS INDICATED AND TO VERIFY CORRECTIVE ACTION.

SETUP ILLUSTRATION OF ROTUNDA™ 014-00761 PRESSURE TEST KIT AND TEST FITTINGS

CONNECT CLEAR PVC TEST HOSE AT CONTINUOUS VENT

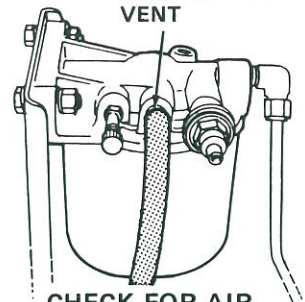

CHECK FOR AIR IN FUEL TEST 6A

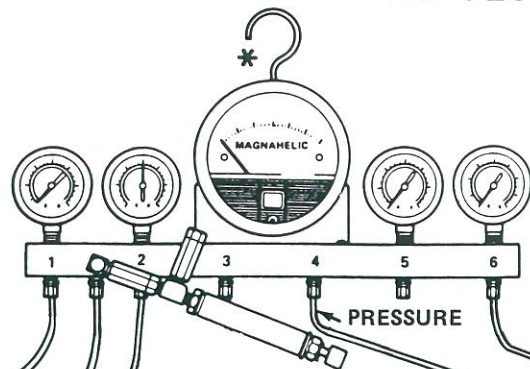

PRESSURE

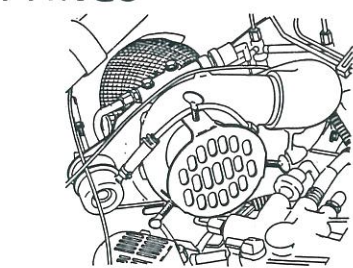

USE GUARD WHEN CHECKING TRANSFER PUMP PRESSURE TEST 12

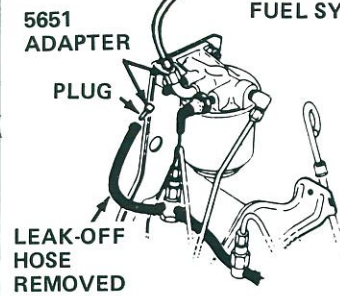
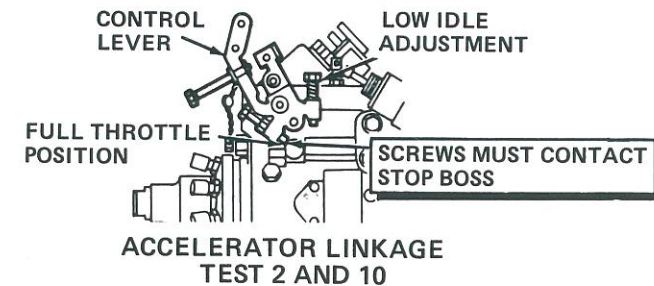
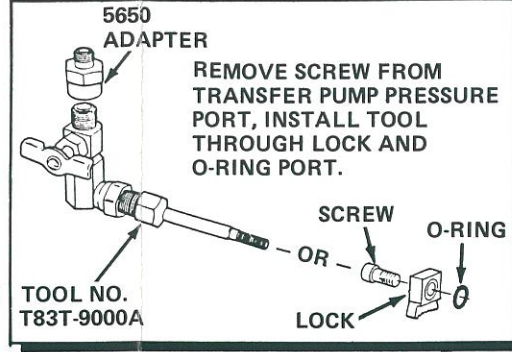

CHECK FUEL FILTER OUTLET PRESSURE TEST 7A

REMOVE FUEL PRIMING VENT

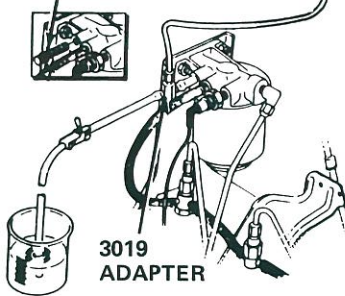

SUPPLY PUMP OUTLET PRESSURE & CAPACITY TEST 7B & C

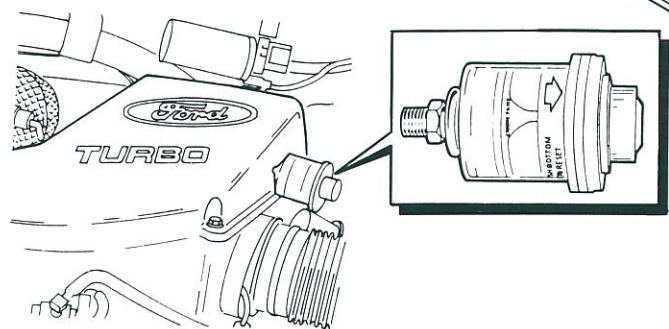

TO 0-15 PSI PRESSURE GAUGE

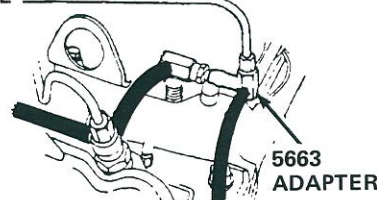

FUEL RETURN LINE PRESSURE TEST 8

TO 0-15 PSI PRESSURE GAUGE

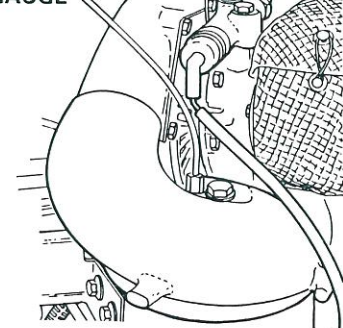

RESTRICTION AT SUPPLY PUMP INLET TEST 7D

TURBOCHARGER BOOST TEST 4

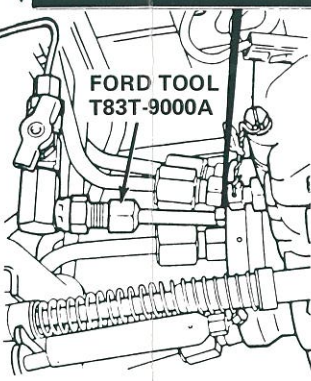

INJECTION PUMP FUEL TRANSFER PRESSURE TEST 12

- LOOSEN CDR FASTENERS
- INSERT CLEAN CARDBOARD BETWEEN CDR VALVE AND SEAL RING
- RETIGHTEN CDR FASTENERS

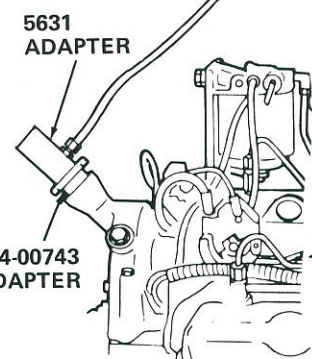

014-00743 ADAPTER

CRANKCASE PRESSURE * TEST 14

TO HAND PUMP

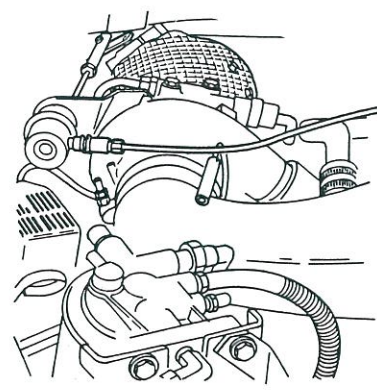

WASTEGATE ACTUATOR TEST 5

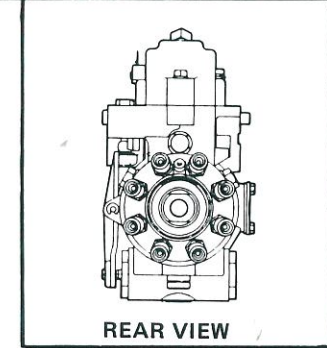
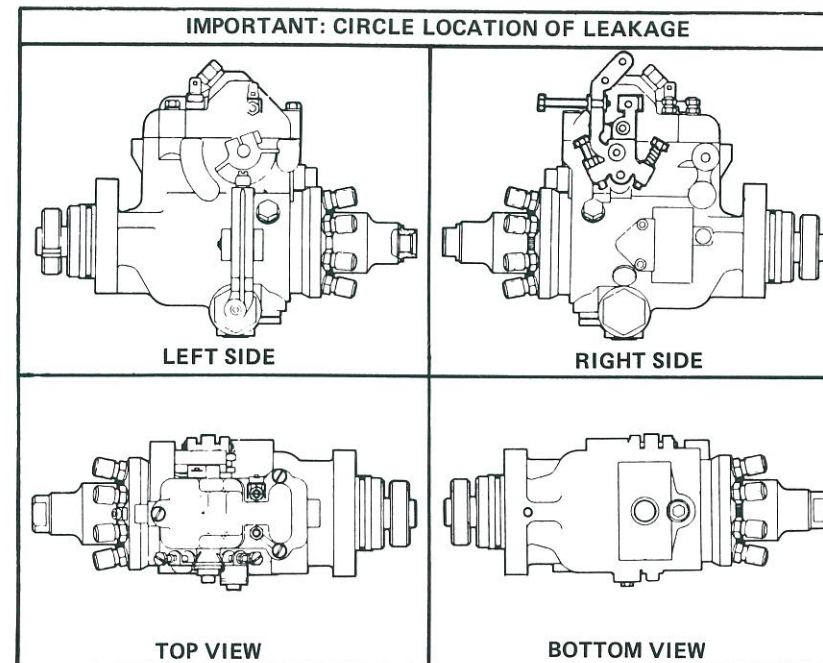

EXTERNAL FUEL LEAKAGE TEST 1

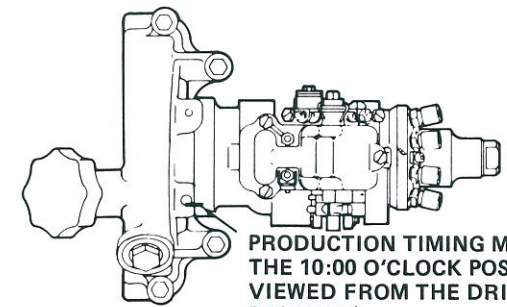
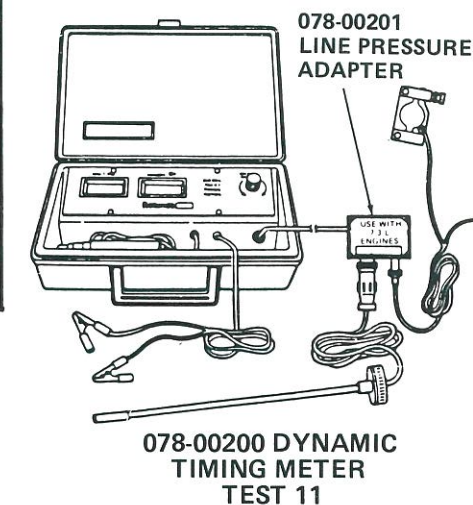
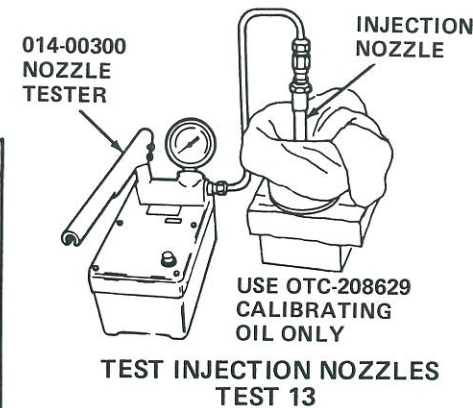

PRODUCTION TIMING MARKS AT THE 10:00 O'CLOCK POSITION (AS VIEWED FROM THE DRIVER'S POSITION).

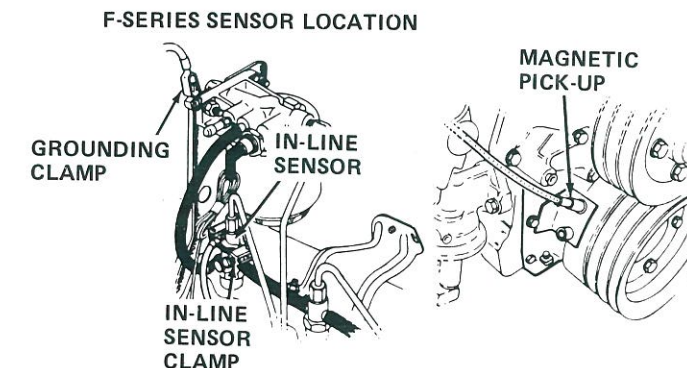

DYNAMIC TIMING SPEC.
8° ± 2° BTDC @ 2000 RPM

ENGINE TIMING SPECIFICATION TEST 11